

# Instructions for Fuel Pressure Tester Kit

## Safety Precautions

To prevent accidents that could result in serious injury and/or damage to your vehicle or test equipment, carefully follow these safety rules and test procedures at all times when working on vehicles.

- Always wear approved eye protection.
- Never use Fuel Pressure Tester Kit on **Diesel** or **Flex Fuel** engines!
- Never attach Fuel Pressure Tester to any place other than the fuel rail test port. Do not confuse Air Conditioning schrader valves with the fuel rail test port.
- Never attach or remove Fuel Pressure Tester from fuel rail test port with the ignition key on.
- Always place end of 6 ft. bleed-off hose in an approved container for fuel during testing and when bleeding off fuel pressure.
- Never smoke or have open flames near vehicle. Vapors from fuel and charging battery are highly flammable and explosive.
- Never permit fuel to spill on hot engine parts. If a spill or leak occurs, immediately turn ignition key off, and clean up fuel.
- Only use the Fuel Pressure Tester Kit for measuring fuel pressure on vehicles having schrader valves as their fuel rail test port. Do not use this kit for any other purpose!
- Always operate the vehicle in a well ventilated area. Do not inhale exhaust gases or fuel vapors - they are very hazardous!
- Always keep yourself, tools and test equipment away from all moving or hot engine parts.
- Always make sure the vehicle is in **PARK** (Automatic transmission) or **NEUTRAL** (manual transmission) and that the **parking brake is firmly set**. Block the drive wheels.
- Never lay tools on vehicle battery. You may short the terminals together causing harm to yourself, the tools or the battery.
- Never leave vehicle unattended while running tests.
- Always keep a fire extinguisher suitable for fuel/electrical/chemical fires handy.
- Always use extreme caution when working around the ignition coil, distributor cap, ignition wires, and spark plugs. These components contain **High Voltage** when the engine is running.
- Complete **all Pre-Testing Checks** before beginning fuel pressure testing.
- Always follow vehicle manufacturer's warnings, cautions and service procedures.

### CAUTION:

Some vehicles are equipped with safety air bags. You *must* follow vehicle service manual cautions when working around the air bag components or wiring. If the cautions are not followed, the air bag may open up unexpectedly, resulting in personal injury. Note that the air bag can still open up several minutes after the ignition key is off (or even if the vehicle battery is disconnected) because of a special energy reserve module.

## Fuel Pressure Tester Description

1. **Dial Face:** Measurement scale that shows amount of fuel pressure present in fuel system.
2. **Pressure Relief Button:** Used to relieve fuel pressure in the gauge hose before disconnecting the gauge hose from the fuel rail.
3. **Bleed-Off Hose:** A 6-ft. hose that bleeds off fuel pressure when the pressure relief button is pressed. Never use a bleed-off hose shorter than 6 ft.  
*Important: Always make sure end of bleed-off hose is in an approved container for fuel at all times during testing and when bleeding off fuel pressure!!*
4. **Gauge Hose:** Hose that carries fuel to the gauge so that pressure can be measured.
5. **GM/Chrysler Test Port Adapter:** This adapter is used to connect the gauge hose to GM and Chrysler vehicles equipped with a schrader valve test port on the fuel rail.
6. **Ford Test Port Adapter:** This adapter is used to connect the gauge hose to Ford vehicles equipped with a schrader valve test port on the fuel rail.

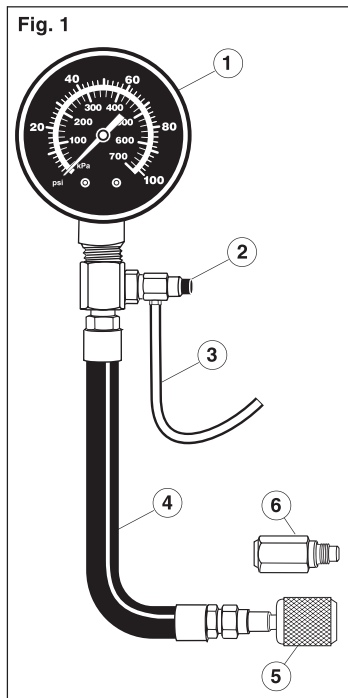

## Fuel Injection System Theory

There are two basic types of fuel injection systems currently being used by GM, Ford, and Chrysler. The first type is called "port" or "multi-port" fuel injection. In this system, the fuel injectors spray fuel directly into the intake manifold behind the intake valve. These systems typically have one fuel injector per cylinder. The second type is commonly called Throttle Body Injection (TBI) for GM and Chrysler vehicles or Central Fuel Injection (CFI) for Ford vehicles. These systems use one or two fuel injectors mounted on top of the intake manifold. They spray fuel into the throttle body similarly to a conventional carburetor. See Fig. 2 for illustrations of both types of fuel systems.

Fig. 2

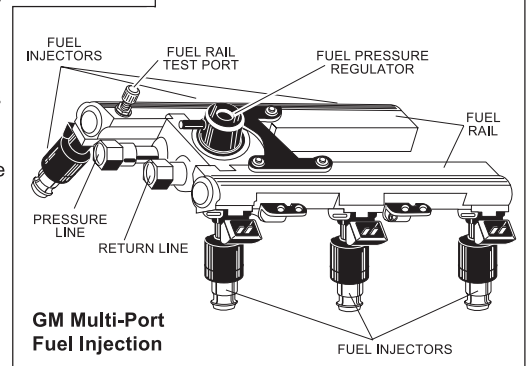
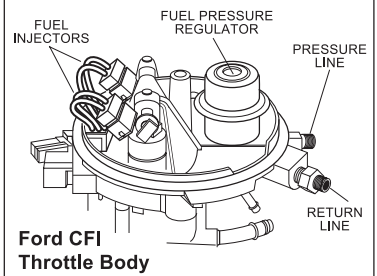

## Fuel System Components

Before doing any fuel pressure testing, it is a good idea to understand how fuel system components work and how they relate to one another. The fuel pump pumps fuel from the fuel tank to the fuel pressure regulator and fuel injectors. The fuel pressure regulator divides fuel between the pressure line and the return line. The fuel in the pressure line goes to the fuel injectors, while the fuel in the return line is returned to the fuel tank.

Fig. 3 shows the orientation of fuel system components in a typical "port" fuel injection system.

**Fuel Tank:** A large container that holds your vehicles supply of fuel.

**Fuel Pump Filter:** A filter that is usually located in the fuel tank. Its function is to prevent foreign particles from reaching the fuel pump. A clogged or restricted fuel pump filter can cause

low fuel pressure readings. When replacing a fuel pump it is a good idea to clean or replace the fuel pump filter.

**Fuel Pump:** An electric motor that pumps fuel into the fuel system at a constant pressure. It is mounted in the fuel tank or on the frame. Some vehicles have more than one fuel pump.

**Return Line:** Path way for excess fuel to return to the fuel tank.

**Pressure Line:** A pressurized fuel line that carries fuel from the fuel tank to the fuel injectors.

**Fuel Filter:** A filter that is located in-line with the pressure line. Its function is to prevent foreign particles from reaching the fuel injectors. A clogged or restricted fuel filter can also cause low fuel pressure readings. This is the only fuel system component that requires periodic replacement. Refer to vehicle owners manual for replacement interval.

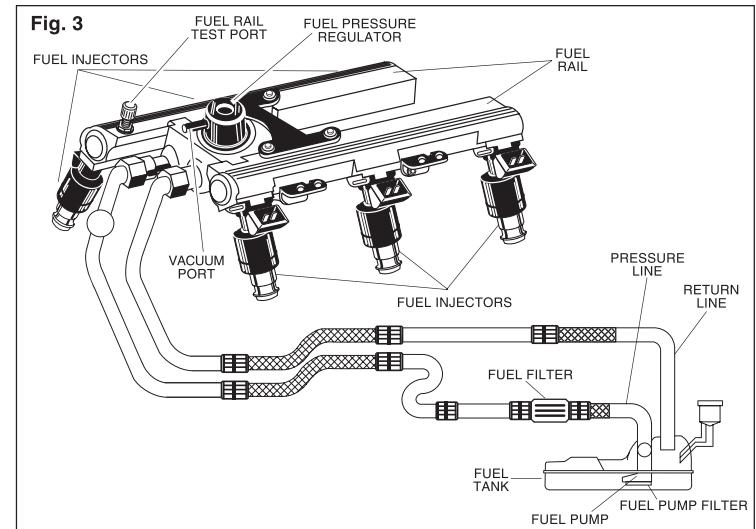

**Fuel Rail Test Port:** A schrader valve located on the fuel rail (Fig. 4) that allows easy connection of a fuel pressure gauge to measure fuel pressure. Do not confuse this valve with the schrader valves that are used for re-charging air conditioning systems.

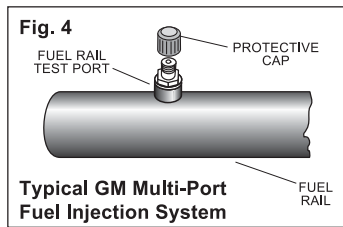

**Fuel Pressure Regulator:** The fuel pressure regulator (Fig. 5) is connected across the pressure line and return line. It contains a spring loaded valve assembly that opens to allow fuel to move into the return line, when the pressure line fuel pressure is exceeded. It is used to keep a constant fuel pressure drop across the fuel injectors. Some fuel pressure regulators have a vacuum port so fuel pressure can be adjusted based on engine load. These are commonly called vacuum actuated (compensated) fuel pressure regulators. A leaking fuel pressure regulator can cause low fuel pressure readings and hard starting problems.

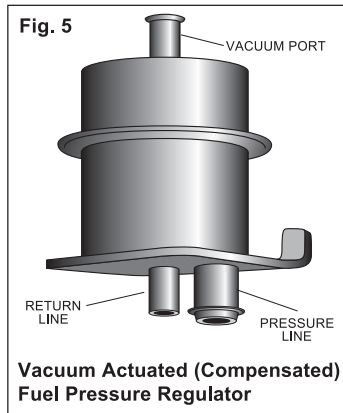

**Fuel Rail:** The fuel rail assembly is bolted to the intake manifold. Its purpose is to hold the fuel injectors in place and to deliver pressurized fuel to the fuel injectors.

**Fuel Injectors:** A precision valve that is controlled by a solenoid. Fuel injection is controlled by the amount of fuel pressure, and the size and duration of the valve opening. Fuel injectors contain a filter used to prevent very small particles from clogging the valve. Leaking fuel injectors will cause fuel pressure to slowly decrease when the ignition key is on and engine is off.

### Fuel Pressure Testing Procedures

This test procedure explains how to make fuel pressure measurements on vehicles while the ignition key is on and while the engine is at idle. The procedure also explains the safest way to connect and disconnect the fuel pressure tester kit from vehicles equipped with schrader valves as their fuel rail test ports. If the fuel pressure readings measured in this test procedure are not within your vehicles manufacturing specification, then you must use your vehicle service manual along with the fuel pressure tester kit to service the problem. This test procedure does not contain any vehicle specific diagnostics.

### Pre-Testing Checks

1. Read Safety Precautions.
2. Do a thorough visual and "hands-on" inspection of the engine and fuel system. Look for loose or cracked electrical wiring, battery cables, ignition wires, and fuel or vacuum lines.
3. Verify that the battery is fully charged and fuel tank has an adequate supply of fuel.
4. Verify that the inertia switch on certain Ford/Lincoln/Mercury vehicles has not been tripped. (The inertia switch is usually located in the trunk.)
5. Verify that all fuel system fuses are good.
6. Verify fuel vapor recovery system and gas cap are in good condition.
7. Verify that manifold vacuum is within manufacturers specification which is typically 18-20 in. at idle.
8. Look for fuel leaks and wipe up any spilled fuel immediately.
9. If engine will not start, check ignition system for spark. If no ignition spark is present, refer to vehicle service manual for No Start Diagnostics.

1. Read all SAFETY PRECAUTIONS and PRE-TESTING CHECKS.
2. Apply a lightweight household oil to the rubber "O" rings inside both test port adapters.
3. Turn Ignition Key OFF.
4. Locate fuel rail test port and remove protective cap. (See Fig. 4.)

*For Ford/Lincoln/Mercury Vehicles...*

- Screw Ford test port adapter to fuel rail test port until finger tight.
- Screw GM/Chrysler test port adapter to the Ford test port adapter until finger tight.

*For GM/Chrysler Vehicles...*

- Screw GM/Chrysler test port adapter to fuel rail test port until finger tight.

**Note:** Always wrap a shop rag around fuel rail test port when attaching test port adapters. This is a precaution in case a small amount of fuel leaks out while attaching adapters.

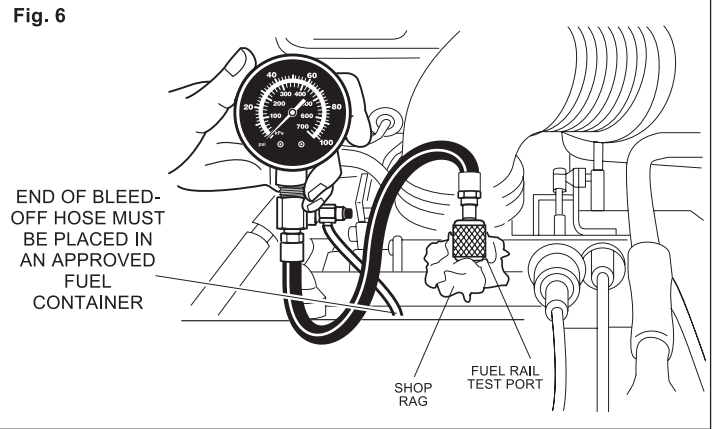

5. Place end of 6 ft. bleed-off hose in an approved container for fuel.

Bleed-off hose must remain in container until testing is complete.

6. Turn all accessories OFF. (i.e. Radio, A/C, Blower Fan, Headlights, Windshield Wipers...)

7. Turn ignition key ON.

Do the following checks...

- Listen for fuel pump. Pump should run for approximately 2 seconds.
- Check fuel system for leaks. If leaks found, turn ignition key OFF and wipe up fuel immediately!
- Read fuel pressure from dial face. Pressure should rise to manufacturers specification and hold steady even after fuel pump stops running. Refer to vehicle service manual for fuel pressure specifications.
- If fuel pressure is not within manufacturers specification, than service vehicle according to vehicle service manual.
- When repair is completed and key-on-engine-off fuel pressure is now within manufacturers specification, then proceed to Step 8.
- For instructions on how to safely disconnect the Fuel Pressure Tester Kit from the fuel rail test port, proceed to Step 9.

8. Start engine – Let idle.

- If your vehicles fuel system uses a vacuum actuated (compensated) fuel pressure regulator then fuel pressure should drop approximately 3-10 psi, depending on manifold vacuum.
- If your vehicles fuel system uses a fuel pressure regulator without a vacuum port than fuel pressure should remain constant during both key-on-engine-off and idle.
- Read fuel pressure from dial face.
- If fuel pressure is not within manufacturers specification, than service vehicle according to vehicle service manual.

- When repair is completed and idle fuel pressure is now within manufacturers specification, then proceed to Step 9.
- To safely disconnect the Fuel Pressure Tester Kit from the fuel rail test port and perform repairs at a later time, proceed to Step 9.

9. Turn Ignition Key OFF.

10. Verify that 6 ft. bleed-off hose is still in an approved container for fuel.

11. Fully DEPRESS and HOLD the pressure relief button until dial face pointer is resting on stop pin.

12. Shake bleed-off hose to make sure that all fuel went into approved container.

13. Remove gauge hose from fuel rail test port.

*For Ford/Lincoln/Mercury Vehicles...*

- Wrap a shop rag around fuel rail test port in case a small amount of fuel drips out while unscrewing test port adapters.
- Unscrew GM/Chrysler test port adapter from Ford test port adapter.
- Wrap a shop rag around GM/Chrysler test port adapter so any fuel dripping from gauge hose is absorbed.

- Remove bleed-off hose from approved fuel container and hold gauge hose over container so any remaining fuel will drip into container.
- Unscrew Ford test port adapter from fuel rail test port.

*For GM/Chrysler Vehicles...*

- Wrap a shop rag around fuel rail test port in case a small amount of fuel drips out while unscrewing test port adapters.
- Unscrew GM/Chrysler test port adapter from fuel rail test port.
- Wrap a shop rag around GM/Chrysler test port adapter so any