



655 Eisenhower Drive
 Owatonna, MN 55060 USA
 Phone: (507) 455-7000
 Tech. Serv.: (800) 533-6127
 Fax: (800) 955-8329
 Order Entry: (800) 533-6127
 Fax: (800) 283-8665
 International Sales: (507) 455-7223
 Fax: (507) 455-7063

Form No. 100607

Parts List for:

1826
 1826A

Hydraulic Shop Press

Maximum Capacity: 25 Tons

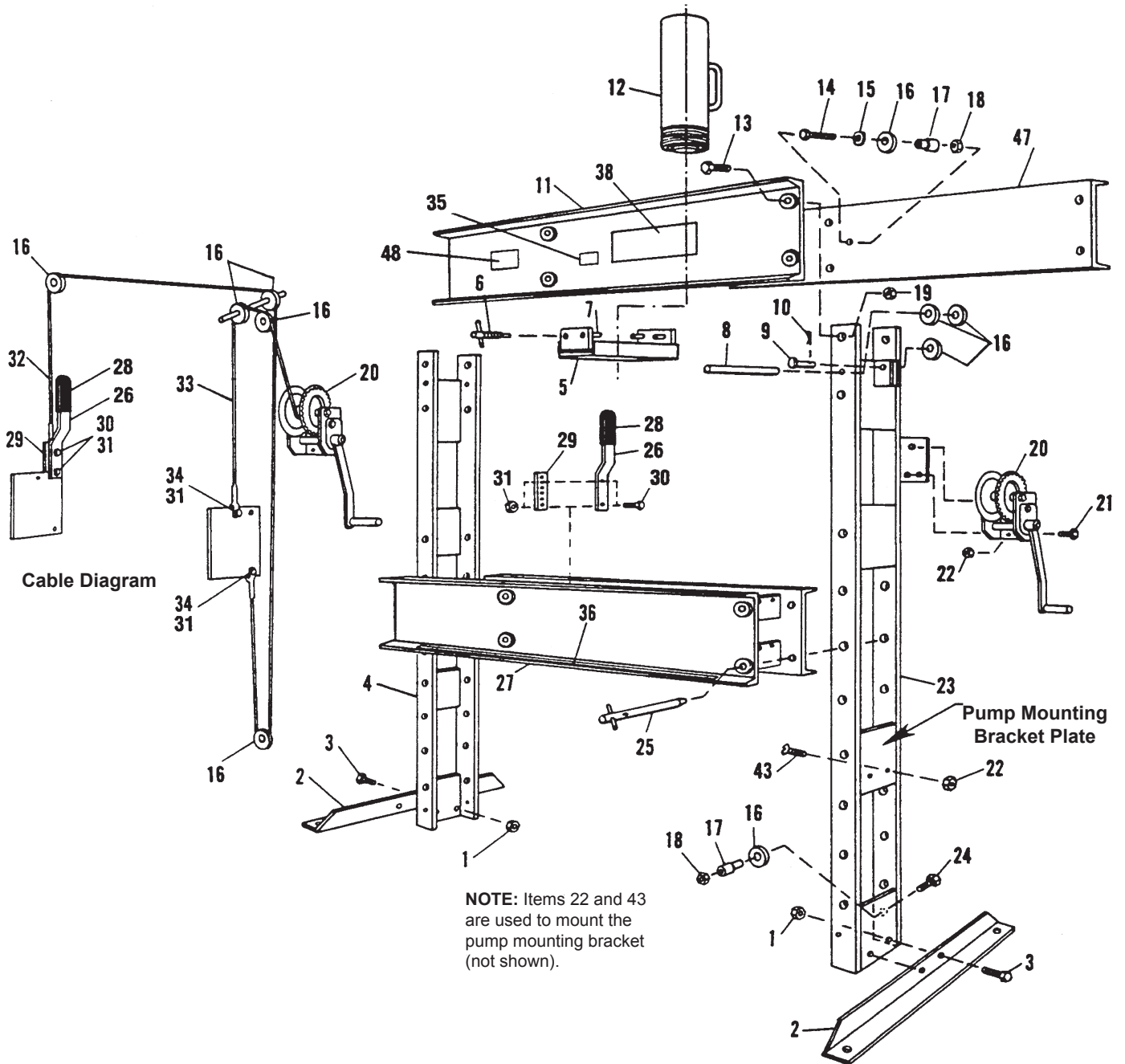

Parts List

Form No. 100607, Sheet 1 of 2, Back

Item No.	Part No.	No. Req'd	Description	Item No.	Part No.	No. Req'd	Description
-	61275	1	Press Frame (Complete frame only.)	22	10204	5	Hex Nut (5/8-16 UNC) (1826)
1	10208	4	Hex Nut (1/2-18 UNC)		10204	3	Hex Nut (5/8-16 UNC) (1826A)
2	304485	2	Angle Foot	23	42466	1	Right-hand Upright
3	11624	4	Hex Hd. Cap Screw (1/2-13 UNC x 1 1/2-in. Lg.)	24	10089	1	Hex Hd. Cap Screw (1/2-13 UNC x 2 1/2-in. Lg.)
4	42462	1	Left-hand Upright	25	25840	4	Pin Assembly
5	42412	1	Plate	26	38579	1	Handle
6	25825	1	Adjusting Screw	27	51510	1	Lower Bolster
7	10611	3	Roll Pin (3/8-in. dia. x 1 1/2-in. Lg.)	28	17241	1	Handle Grip
8	202469	1	Pulley Axle	29	201929	1	Cable Adjuster Strap
9	16654	1	Clevis Pin	30	10017	2	Hex Hd. Cap Screw (1/4-20 UNC x 1-in. Lg.)
10	10472	1	Cotter Pin	31	12809	4	Locknut (1/4-20 UNC)
11	32578	1	Upper Front Bolster	32	202473	1	Press Cable
12	52025	1	25-Ton Hydraulic Cylinder	33	204728	1	Winch Cable
13	12687	8	Hex Hd. Cap Screw (7/8-9 UNC x 2 1/4-in. Lg.)	34	10019	2	Hex Hd. Cap Screw (1/4-20 UNC x 1 1/4-in. Lg.)
14	12896	1	Hex Hd. Cap Screw (1/2-13 x 2 1/4-in. Lg.)	35	206043	1	Instruction Decal
15	12004	1	SAE Washer (1/2-in. bolt)	36	46896	1	Warning Decal
16	16653	5	Pulley (2 1/2-in. dia.)	38	14601	1	25-Ton Press Decal
17	202468	2	Spacer	43	10189	2	Flat Hd. Machine Screw (Used on 1826 only)
18	15013	2	Locknut (1/2-13 UNC)	47	33335	1	Upper Rear Bolster
19	10219	8	Hex Nut (7/8-9 UNC)	48	14401	1	Open Throat Decal
20	18895-1	1	Winch	49	12004	4	Washer (Not shown, used with Item No. 1)
21	10049	3	Hex Hd. Cap Screw (5/8-16 UNC x 1-in. Lg.)				

Refer to any operating instructions included with this product for detailed information about operation, testing, disassembly, reassembly, and preventive maintenance.

Items found in this parts list have been carefully tested and selected. **Therefore: Use only genuine replacement parts!**

Additional questions can be directed to our Technical Services Department.

Hand Pump

(Used on 1826)

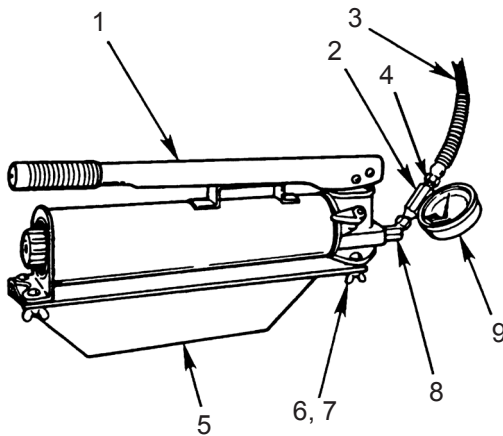

Item No.	Part No.	No. Req'd	Description
1	4016	1	Hand Pump
2	24815	1	Tee Adapter
3	303563	1	Hydraulic Hose
4	10469	1	Straight Fitting
5	42733	1	Pump Mounting Bracket
6	10590	3	Wing Nut
7	12680	3	Thumb screw
8	10648	1	45° Elbow
9	16715	1	Gauge

Air Pump

(Used on 1826A)

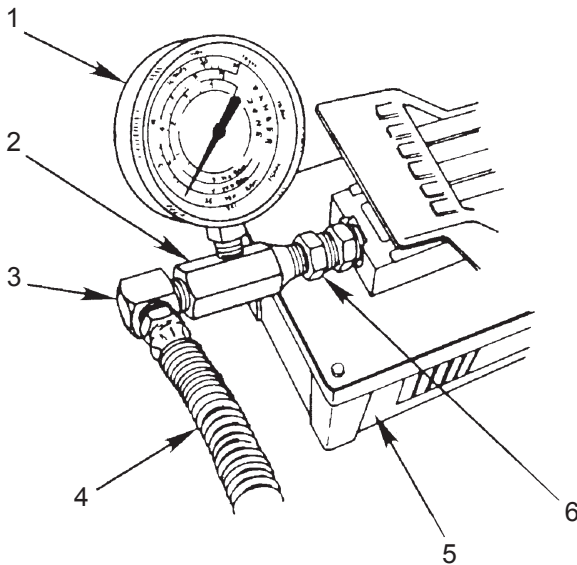

Item No.	Part No.	No. Req'd	Description
1	16715	1	Gauge
2	24815	1	Tee Adapter
3	10474	1	90° Elbow
4	303563	1	Hydraulic Hose
5	4020	1	Air Pump
6	10469	2	Straight Fitting