



SPX Corporation  
 655 Eisenhower Drive  
 Owatonna, MN 55060-0995 USA  
 Phone: (507) 455-7000  
 Tech. Serv.: (800) 533-6127  
 Fax: (800) 955-8329  
 Order Entry: (800) 533-6127  
 Fax: (800) 283-8665  
 International Sales: (507) 455-7223  
 Fax: (507) 455-7063

Form No. 102489

Operating Instructions for:

014-00071B	61146
014-00072B	61147
016-00029	ADCE-61146
016-00030	D-01001AA
1819	D-01002AA
1820	

Heavy Duty  
 Mobile Floor Crane

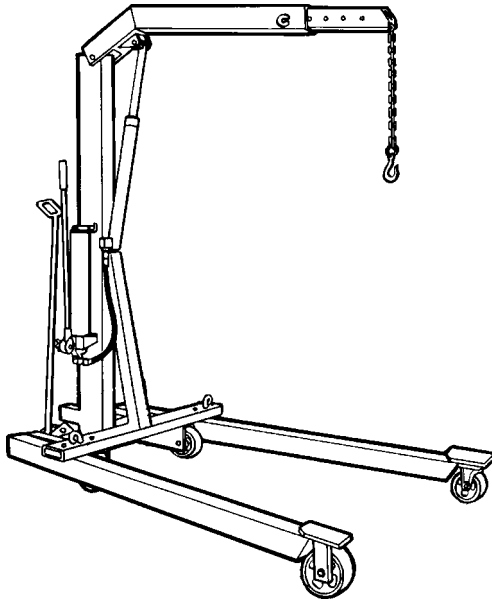

<b>Max. Capacity</b>	014-00071B	014-00072B
	016-00029	016-00030
	1819, 61146	1820, 61147
	ADCE-61146	D-01002AA
	D-01001AA	
Boom retracted	2,200 lbs.	4,400 lbs.
Boom extended	1,650 lbs.	3,300 lbs.

**Safety Precautions**



**CAUTION:** To help prevent personal injury and/or equipment damage,

- Read and carefully follow the safety precautions and operating instructions for this floor crane and the pump and ram used with this floor crane. Most problems with new equipment are caused by incorrect operation or assembly.
- Wear eye protection that meets the requirements of ANSI Z87.1 and OSHA.
- Do not raise the boom with the legs in the upright position; the legs must be pinned through the cross member.
- The maximum relief valve pressure setting of any power source used with this floor crane must not exceed 8,800 PSI.
- Never attempt to lift a load heavier than the rated capacity of the crane boom, because overloaded equipment can fail.
- Stay out from underneath a load being lifted or suspended.
- To prevent tipping: do not lift or move a load that has a center of gravity extending beyond the legs or wheels; do not move a loaded crane unless the load has been lowered as close to the floor as possible; use extreme caution when moving a loaded crane on an incline or around a corner, because the load can swing out beyond the wheels and cause the crane to tip over.
- Do not modify this floor crane. If a modification is needed, contact OTC Division Technical Services.
- The owner of the crane is responsible for ensuring that procedures are followed according to federal, state, and local safety regulations.

Sheet No. 1 of 1

Issue Date: Rev. B, 7-31-02

### Setup

1. Remove banding material and tape.
2. Locate pins, chain assembly, and small parts packed in a carton attached to the floor crane.
3. Remove the pump and hose assembly from the shipping carton.
4. Position the legs under the cross member:
  - a. Grasp one of the legs, and remove the leg catch pin holding the leg in an upright position against the crane mast. See Figure 1.
  - b. Slowly swing the leg back and down, and then under the cross member.
  - c. Lock the leg in place by sliding the pin through the cross member and into the leg.
  - d. Repeat Steps 4a - 4d for the other leg.

**Caution:** Legs must be locked in place under the cross member; if the legs are not locked in place, the floor crane can tip, possibly causing personal injury.

5. Arrange the pump on the crane mast with the hose end on the bottom. Thread four 1/4 dia. x 1" lg. cap screws through the pump base into the mast. See Figure 2.
6. Attach the hose to the bottom of the cylinder. **Note: Seal hydraulic connections with Bakerseal or one layer of Teflon tape.** Apply the tape carefully to prevent it from being pinched by the fitting and broken off inside the pipe end. Loose pieces of tape could travel through the system and obstruct the flow of oil or cause jamming of precision-fit parts.
7. Bleed air from the hydraulic system:
  - a. Remove the cylinder from the floor crane, and turn it upside down so the bleed screw is on top.
  - b. Loosen the bleed screw.
  - c. Slowly operate the pump until a clear stream of hydraulic oil (no bubbles) flows from the bleed port.
  - d. Tighten the bleed screw.
  - e. Mount the cylinder on the floor crane.

**Caution:** The cylinder must be bled to remove air because air in the hydraulic system could cause a suspended load to drop unexpectedly.

8. Hook the chain to the boom extension.
9. To move the floor crane, pull the dolly handle DOWN, and position the crane as needed. Move the dolly handle to the UP position.

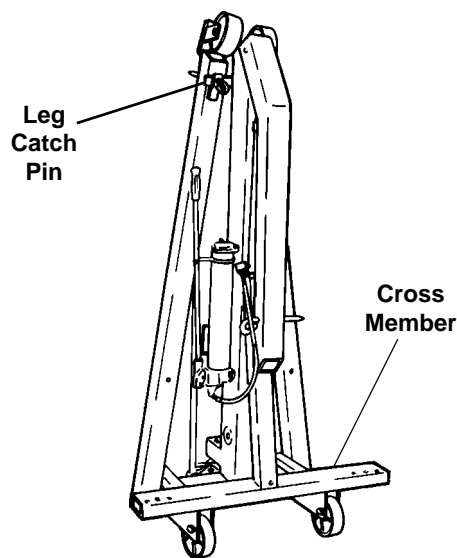

Figure 1

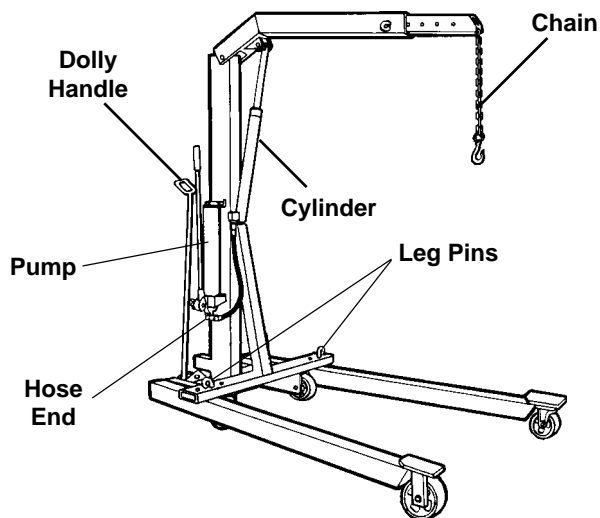

Figure 2

### Maintenance

- Maintain the hydraulic fluid according to the instructions included with the pump and cylinder. Use high-grade hydraulic oil such as OTC #9037; do NOT use brake fluid, because brake fluid can damage the internal seals of the pump and cylinder. Completely retract the cylinder before adding or replacing oil.
- Grease the wheels and pivot points on a regular maintenance schedule.
- Periodically inspect the hydraulic hose for cuts and abrasions, and replace the hose if there are signs of wear.
- To store the floor crane, slowly open the pump control valve to lower the boom to the mast. Remove the leg pins, and pull the legs out from under the cross member. Raise the legs to the mast and pin them to the leg catches.
- If the lifting action of the hydraulic system feels "spongy," bleed air out of the cylinder as outlined in Step 7 of the setup instructions.