



SPX Corporation
 655 Eisenhower Drive
 Owatonna, MN 55060-0995 USA
 Phone: (507) 455-7000
 Tech. Serv.: (800) 533-6127
 Fax: (800) 955-8329
 Order Entry: (800) 533-6127
 Fax: (800) 283-8665
 International Sales: (507) 455-7223
 Fax: (507) 455-7063

Operating Instructions for:

1U-5230 (See 4002)	4012	61869 (See 4016)
4000	543158	61871 (See 4016)
4002	4016	61872 (See 4016)
4002-ER (See 4002)	4017	JTO5845
4008	61522 (See 4002)	(See 4016)
4009	61821 (See 4016)	

**SINGLE-STAGE AND TWO-STAGE
 HYDRAULIC HAND PUMP**
 Max. Pressure: See Pump Data Plate

Definition: A hydraulic hand pump delivers hydraulic fluid under pressure by directly applied manual effort.

Note: Illustrations depict general pump configurations.

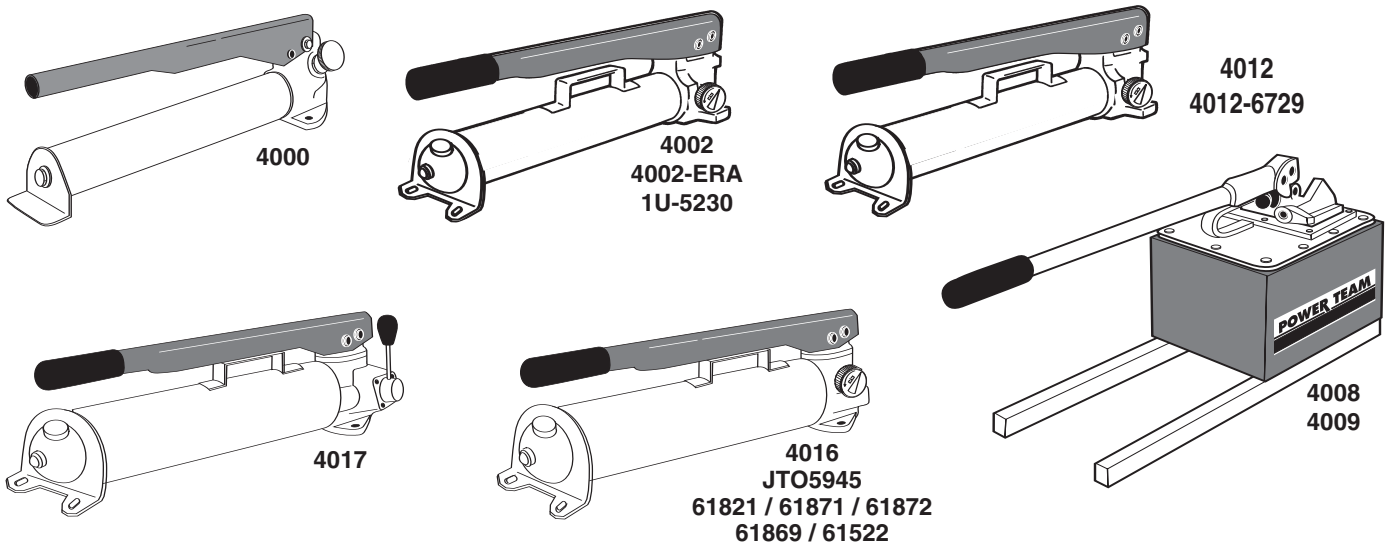

For Use With	Order No.	Volume & Pressure					Handle Effort		Reservoir				Product Weight		
		Stage	Volume per Stroke		Maximum Pressure				Type	Oil Capacity		Usable Oil Capacity			
			In. ³	cm ³	psi	bar	lbs.	kg		In. ³	cm ³	In. ³	cm ³	lbs.	kg.
Single-Acting Cylinders (Pump includes 2-Way Valve)	4000	1	0.069	1.1	10000	700	75	34.0	A	12	197	9	148	5.7	2.6
	4002	1	0.160	2.6	10000	700	145	65.8	B	55	901	45	738	15.8	7.2
	4012	1	0.662	10.8	325	22	145	65.8	B	55	901	45	738	17.2	7.8
		2	0.160	2.6	10000	700									
	4012-Q6729	1	0.662	10.8	325	22	145	65.8	B	55	901	45	738	17.2	7.8
		2	0.160	2.6	2,700	190									
4016	1	2.600	42.6	325	22	140	63.5	B	152	2491	137	2245	26.0	11.8	
	2	0.160	2.6	10000	700										
4008	1	7.350	120.5	325	22	90	40.8	C	2.5 gal.	9.5 l	460	7539	54.9	24.9	
	2	0.294	4.6	10000	700										
Double-Acting Cylinders	4017	1	2.600	42.6	325	22	140	63.5	B	152	2491	137	2245	27.9	12.7
		2	0.160	2.6	10000	700									
(Pump includes 4-Way Valve)	4009	1	7.350	120.5	325	22	90	40.8	C	2.5 gal.	9.5 l	460	7539	57.9	26.3
		2	0.294	4.6	10000	700									

3/8 NPTF oil port(s) on all pumps

Table 1

SAFETY EXPLANATIONS

Two safety symbols are used to identify any action or lack of action that can cause personal injury. Your reading and understanding of these safety symbols is very important.

 **DANGER** - Danger is used only when your action or lack of action will cause serious human injury or death.

 **WARNING** - Warning is used to describe any action or lack of action where a serious injury can occur.

IMPORTANT - Important is used when action or lack of action can cause equipment failure, either immediate or over a long period of time.

Pictogram Definition



Do not remove this component. For service only. Pressure must be released.

 **WARNING:** It is the operator's responsibility to read and understand the following safety statements,

- Only qualified operators should install, operate, adjust, maintain, clean, repair, or transport this machinery.
- These components are designed for general use in normal environments. These components are not specifically designed for lifting and moving people, agri-food machinery, certain types of mobile machinery or special work environments such as: explosive, flammable or corrosive. Only the user can decide the suitability of this machinery in these conditions or extreme environments. OTC will supply information necessary to help make these decisions.

These instructions are intended for end-user application needs. Most problems with new equipment are caused by improper operation or installation. Detailed service repair instructions or parts lists can be obtained from your nearest OTC facility.

SAFETY PRECAUTIONS



WARNING: To help prevent personal injury,

- Before operating the pump, all hose connections must be tightened with the proper tools. Do not overtighten. Connections need only be tightened securely and leak-free. Overtightening may cause premature thread failure or high pressure fittings to split at pressures lower than their rated capacities.
- Should a hydraulic hose ever rupture, burst, or need to be disconnected, immediately shut off the pump and shift the control valve twice to release all pressure. Never attempt to grasp a leaking hose under pressure with your hands. The force of escaping hydraulic fluid could cause serious injury.
- Do not subject the hose to any potential hazard such as fire, extreme heat or cold, sharp surfaces, heavy impact. Do not allow the hose to kink, twist, curl, or bend so tightly that the fluid flow within the hose is blocked or reduced. Periodically inspect the hose for wear because any of these conditions can damage the hose and result in personal injury.
- Do not use the hose to move attached equipment. Stress may damage the hose and cause personal injury.
- Hose material and coupler seals must be compatible with the hydraulic fluid used. Hoses also must not come in contact with corrosive materials such as creosote-impregnated objects and some paints. Consult the manufacturer before painting a hose. Never paint the couplers. Hose deterioration due to corrosive materials may result in personal injury.
- All components in the hydraulic system must match the maximum pressure rating of the pump.

Pump

- Do not exceed the PSI rating noted on the pump nameplate or tamper with internal high pressure relief valve. Creating pressure beyond rated capacities may result in personal injury.
- Before adding hydraulic fluid, retract the system to prevent overflowing the pump reservoir. An overflow may cause personal injury due to excess reservoir pressure created when cylinders are retracted.
- The load must be under operator control at all times.

Cylinder

- Do not exceed rated capacities of the cylinders. Excess pressure may result in personal injury.
- Do not set poorly-balanced or off-center loads on a cylinder. The load may tip and cause personal injury.
- Stay clear of lifted loads and keep others away.
- Extensions are not recommended for lifting applications.

SET-UP

Hydraulic Connections

IMPORTANT: Seal all hydraulic connections with a high grade, nonhardening thread sealant. Teflon tape may also be used to seal hydraulic connections if only one layer of tape is used. Apply the tape carefully, two threads back, to prevent it from being pinched by the coupler and broken off inside the pipe end. Any loose pieces of tape could travel through the system and obstruct the flow of fluid or cause jamming of precision-fit parts.

1. Clean all areas around the fluid ports of the pump and cylinder. Clean all hose ends, couplers, and union ends. Remove thread protectors from the hydraulic fluid outlets, and connect the hose assembly. Couple hose to cylinder.
2. The use of a hydraulic pressure or tonnage gauge (not included) is strongly recommended. Remove the pipe plug from the gauge port of the valve, thread the gauge into this port and seal as noted above.



WARNING: To help prevent personal injury,

- The gauge must have the same pressure rating as the pump and cylinder. Personal injury can result if the wrong gauge is used.
- Release hydraulic pressure **BEFORE** removing or tightening hose couplings.

OPERATION

The 4008 can be operated only in the horizontal position. All other hand pumps can be operated in a horizontal position or in a vertical position with head pointing downward.

Refer to Table 1 and your pump name plate to determine your style of pump.

IMPORTANT: Figure 1 illustrates the *normal* drop of handle effort experienced when all (*except 4012 and 543158*) two-stage pumps shift from low pressure stage to high pressure stage.

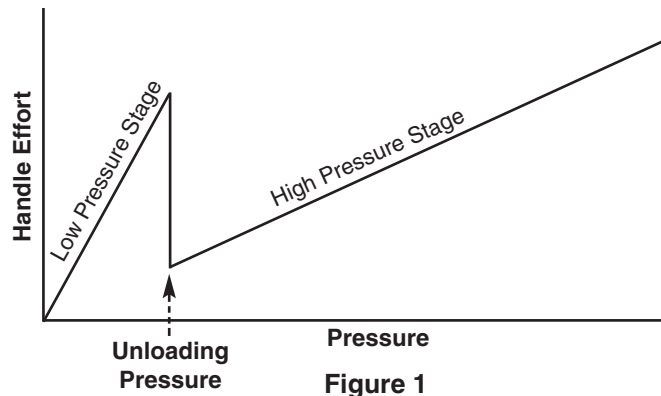

Two-way Valve

Pumps with a two-way valve are for use with single-acting cylinders.

1. To extend the cylinder, turn the valve knob clockwise to a closed (seated) position. **Note: Hand tight only!** Work the pump handle up and down to build pressure.
2. To release pressure, open the valve slowly by turning the knob counterclockwise to control the load.

Four-way Valve

Pumps with a three-position, four-way valve are for use with double-acting cylinders. The hose connection for extending a cylinder can be made to either port. With the handle in the forward position, the fluid is directed to the top fluid port. To maintain (hold) pressure, stop the pumping action. When the valve handle is in the center position, fluid flow is blocked to both ports.



WARNING: The operator should always release the pressure slowly.

PREVENTIVE MAINTENANCE

IMPORTANT: Any repair or servicing that requires dismantling the pump must be performed in a dirt-free environment by a qualified technician.

Lubrication

Apply lubricant regularly to all pivot and rubbing points. Use a good grade of No. 10 motor oil or grease. Do not use dry lubricants.

Bleeding Air From the System

Air can accumulate in the hydraulic system during the initial set-up or after prolonged use, causing the cylinder to respond slowly or in an unstable manner. To remove the air:

1. Position the cylinder at a lower level than the pump, and turn the cylinder rod end down.
2. Extend and retract the cylinder several times without putting a load on the system. Air will be released into the pump reservoir. Follow the fluid level instructions for your reservoir type, release the air from the reservoir, and top off the fluid supply.

Bleeding Air From The Pump

When the pump is first put into use, or after refilling the pump's reservoir it may be necessary to bleed any trapped air from the pump. If this is not done the pump will not function properly (will not build pressure or has very spongy operation).

To bleed air from the pump, turn the pressure control knob counterclockwise (CCW) and operate the pump handle up and down approximately twenty times. Turn the pressure control knob clockwise (CW) to its full stop position. The pump should now be bled of air and ready to use.



Hydraulic Fluid Level

WARNING: Cylinder(s) must be fully retracted before checking the fluid level. Release all system pressure before breaking any hydraulic connection in the system.

Check the hydraulic fluid level in the reservoir periodically. Use a funnel with a filter to add hydraulic fluid if needed.

Refer to Table 1 for your reservoir type.

For models with Reservoir Type A: Place the pump in a vertical position with the pump head facing upward. Unscrew and remove the pump head from the reservoir. The fluid level within the reservoir should come to the fluid level mark indicated on the reservoir body decal. Before replacing the pump head, visually inspect the o-ring which seals the pump head/reservoir assembly. Replace this o-ring if it is worn or damaged. Reinstall pump head to reservoir and tighten securely. Check for leaks.

For models with Reservoir Type B: Remove the filler cap.

The fluid level should come to the bottom edge of the filler hole when the pump is level and resting horizontally on its base and the cylinders are retracted (see Figure 2 - appropriate view depends on model of pump).

For models with Reservoir Type C: Remove the filler cap.

The fluid level should be 1/2 inch (12.7 mm) from the cover plate when the pump is level and resting horizontally on its base and the cylinders are retracted.

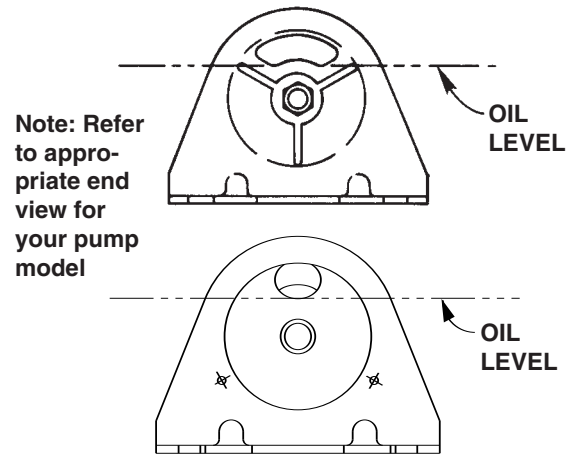

Figure 2

Draining And Flushing The Reservoir

Drain, clean and replenish the reservoir with high-grade, approved hydraulic fluid yearly or more often if necessary. The frequency of fluid change will depend upon the general working conditions, severity of use and overall cleanliness and care given the pump.

IMPORTANT: Clean the exterior of the pump first. After draining and flushing the reservoir, drain and clean the other hydraulic system components (hoses, cylinders, etc.) before connecting them to the pump again. This will help prevent contaminated fluid from entering the pump.

Refer to Table 1 for your reservoir type.

For models with Reservoir Type A:

1. Unthread and separate the pump head from the reservoir. Drain the reservoir of the used hydraulic fluid.
2. Flush out reservoir with a small amount of clean hydraulic fluid. Clean the pump intake filter.

IMPORTANT: Removing the filter from the pump assembly could result in its breakage. Attempt to clean it as well as possible with it installed.

3. Refill the reservoir and reassemble the pump head to the reservoir. Tighten securely. Check for leaks.

For models with Reservoir Type B:

1. Remove the filler cap. Drain the hydraulic fluid through filler hole.
2. Remove the nut from the tie rod. Separate the reservoir from the pump body. Clean the reservoir and filter.

IMPORTANT: Removing the filter from the pump assembly could result in its breakage. Attempt to clean it as well as possible with it installed.

3. Reassemble and fill the reservoir with hydraulic fluid. Replace the filler cap.

For models with Reservoir Type C:

1. Remove the ten screws fastening the reservoir cover to the reservoir, and lift the pump and valve assemblies off.
2. Drain all hydraulic fluid and flush reservoir with a small amount of clean hydraulic fluid.
3. Remove the pump assembly filter, rinse it clean, and reassemble.
4. Refill the reservoir with hydraulic fluid. Place the pump and valve assembly (with gasket) on the reservoir, and thread the ten screws.

Tighten securely and evenly.

TROUBLE-SHOOTING



WARNING: To help prevent personal injury, always release pump pressure and disconnect hoses(s) from pump before making repairs.

Refer to the appropriate pump parts list during trouble-shooting. Repairs must be performed in a dirt-free environment by qualified personnel familiar with this equipment.

PROBLEM	CAUSE	SOLUTION
Pump losing pressure	<ol style="list-style-type: none"> 1. System components leaking 2. Directional control valve leaks or not adjusted properly 3. Fluid leaking past outlet check seat(s) 	<ol style="list-style-type: none"> 1. Repair or replace as necessary 2.* Reseat, repair, or replace directional control assembly and correctly adjust 3.* Check for dirt. Reseat pump body and/or replace poppet(s) or ball(s)
Handle rises after each stroke	<ol style="list-style-type: none"> 1. Fluid leaking past outlet check seat(s) 	<ol style="list-style-type: none"> 1.* Check for dirt. Reseat pump body and/or replace poppet(s) or ball(s)
Pump not delivering fluid	<ol style="list-style-type: none"> 1. Low fluid level in reservoir 2. Intake filter is dirty 3. Seats worn and not seating properly 	<ol style="list-style-type: none"> 1. Check fluid level per instructions 2. Remove reservoir and clean 3.* Repair seats or replace pump body
Pump does not reach full pressure	<ol style="list-style-type: none"> 1. Low fluid level in reservoir 2. System components leaking 3. Directional control valve leaks or not adjusted properly 4. Improperly adjusted relief valve 5. Fluid leaking past inlet or outlet checks or high pressure piston seal damaged 	<ol style="list-style-type: none"> 1. Check fluid level per instructions 2. Repair or replace as necessary 3.* Reseat, repair, or replace directional control assembly and correctly adjust 4.* Readjust 5.* Reseat or repair inlet or outlet checks or replace high pressure piston seal
Pump handle can be pushed down (slowly) without raising the load	<ol style="list-style-type: none"> 1. Inlet checks are not seating 2. Damaged piston assembly or piston seals leaking 	<ol style="list-style-type: none"> 1.* Check for dirt and/or reseat valve seats 2.* Replace piston assembly and/or piston seals
Pump handle operates with a spongy action	<ol style="list-style-type: none"> 1. Air trapped in system 2. Too much fluid in reservoir 	<ol style="list-style-type: none"> 1. Position cylinder lower than pump. Extend and return cylinder several times. Follow bleeding instructions. 2. Check fluid level per instructions
Pump handle effort drops significantly after some pressure has been obtained	<ol style="list-style-type: none"> 1. This is normal operation on most two-stage hand pumps 	

*OTC recommends these hand pump repairs be performed by an Authorized Hydraulic Service Center.