



SPX Corporation  
655 Eisenhower Drive  
Owatonna, MN 55060-0995 USA  
Phone: (507) 455-7000  
Tech. Serv.: (800) 533-6127  
Fax: (800) 955-8329  
Order Entry: (800) 533-6127  
Fax: (800) 283-8665  
International Sales: (507) 455-7223  
Fax: (507) 455-7063

Form No. 102898

Operating Instructions for:

4235

## MODELS A, B, & C IN-LINE HYDRAULIC TESTER



The 50 GPM (200 L/Min.) in-line hydraulic flow tester is a compact, self contained, portable instrument for testing hydraulic systems in the shop or field. Before using the tester, read and understand these instructions.

### SAFETY PRECAUTIONS



#### WARNING

To help avoid personal injury,

- Before operating the tester, all hose connections must be tightened with the proper tools. Do not overtighten. Connections need only be tightened securely and leak-free. Overtightening may cause premature thread failure or high pressure fittings to split at pressures lower than their rated capacities.
- Should a hydraulic hose ever rupture, burst, or need to be disconnected, immediately shut off the tester and shift the control valve twice to release all pressure. Never attempt to grasp a leaking hose under pressure with your hands. The force of escaping hydraulic fluid could cause serious injury.
- Do not subject the hose to any potential hazard such as fire, extreme heat or cold, sharp surfaces, heavy impact. Do not allow the hose to kink, twist, curl, or bend so tightly that the oil flow within the hose is blocked or reduced. Periodically inspect the hose for wear because any of these conditions can damage the hose and result in personal injury.
- Do not use the hose to move attached equipment. Stress may damage the hose and cause personal injury.
- Hose material and coupler seals must be compatible with the hydraulic fluid used. Hoses also must not come in contact with corrosive materials such as creosote-impregnated objects and some paints. Consult the manufacturer before painting a hose. Never paint the couplers. Hose deterioration due to corrosive materials may result in personal injury.

#### IMPORTANT:

- Clean the areas around the oil ports of the tester.
- Inspect all threads and fittings for signs of wear or damage and replace as needed. Clean all hose ends, couplers, or union ends.
- Seal all pipe connections with a high-grade, nonhardening thread sealant. Teflon tape may also be used to seal hydraulic connections, provided only one layer of tape is used. Apply the tape carefully, two threads back, to prevent it from being pinched by the coupler and broken off inside the pipe end. Any loose pieces of tape could travel through the system and obstruct the flow of oil or cause jamming of precision-fit parts.

Sheet No. 1 of 3

Rev. Date: 27 Aug. 1996

## PREPARATION AND SET-UP

The in-line hydraulic tester is shipped with plastic plugs in the inlet and outlet ports. Two adapter unions for 3/4" NPT male fittings in the inlet and outlet ports are included. Remove the plastic plugs and install the appropriate fittings and hoses. Save the plastic port plugs for use during storage to prevent internal contamination of the tester. See Figure 2.

## TESTER COMPONENTS

### Flow Gauge

The flow gauge is a single range gauge.

### Pressure Gauge

Pressure readings are taken from a single fluid-filled pressure gauge, 0-5000 PSI, 0-345 bar. An optional conversion kit (#307281) is available to more accurately isolate pressures in the 0-600 PSI range.

### Pressure Control Valve

The pressure (load) control valve regulates system pressure by restricting the flow to develop back pressure in the system. To increase pressure, turn the control valve clockwise; to reduce pressure, turn control valve counterclockwise.

**IMPORTANT:** Before testing the system, open the pressure control valve all the way by turning the handle counterclockwise. Increase pressure slowly and carefully.

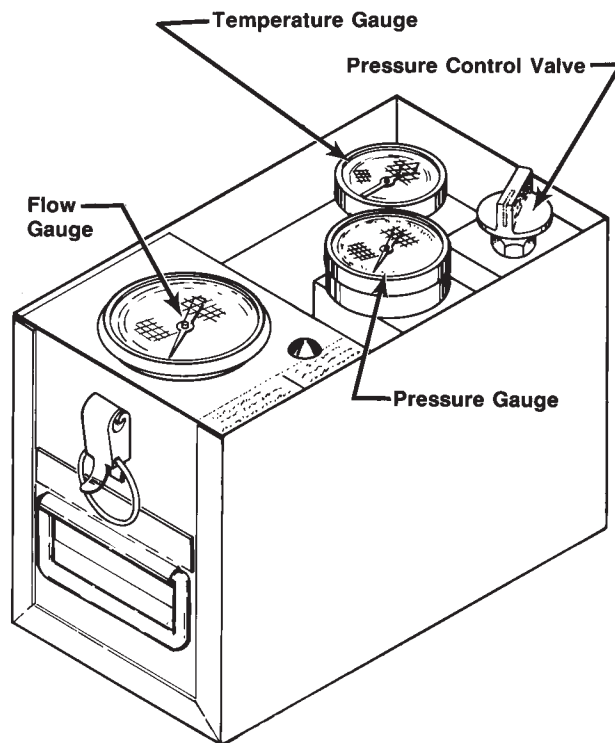

FIGURE 1

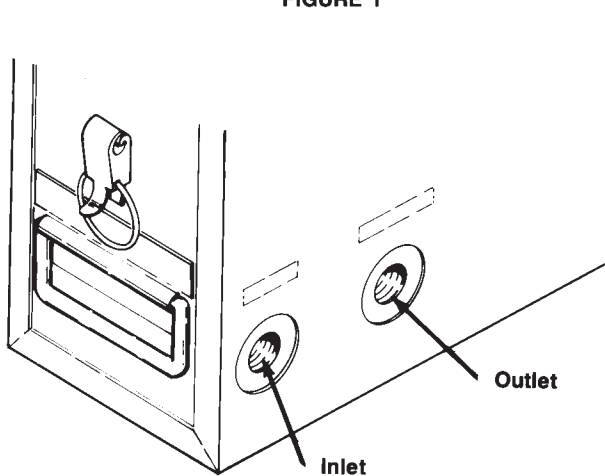

FIGURE 2

### NOTE:

- Adjustment of the pressure control valve may become difficult when connected into a closed center system or when high back pressure is encountered.
- Each time the flow tester is connected to a hydraulic system for testing, the unit may be noisy the first time pressure is increased with the pressure control valve. The noise is caused by air trapped in the internal parts of the control valve. To flush air out, increase pressure to approximately 2000 PSI and then back to 0 PSI.
- Oil the pressure control valve periodically.

### Temperature Gauge

The oil temperature reading is constantly indicated on both a Fahrenheit (20-240°F) and Centigrade (-6-114°C) scale on the temperature gauge.

**Overload Safety Relief Valve Disc**

The INLET and OUTLET sides of the hydraulic tester are protected from excessive pressure by a Safety Relief Disc Assembly (#16230).

If tested pressure exceeds the hydraulic pressure listed below, the disc ruptures, relieving the oil pressure before damage may occur. When the disc bursts, the case will be filled with hydraulic oil.

The Safety Relief Valve Disc Assembly (#16230) must be replaced after it has burst. See Parts List for location.

**NOTE: An extra Safety Relief Valve Disc Assembly is supplied with each unit.**

	<u>Safety Disc Burst Range</u>
50 GPM Tester. . . . .	5510/6093 P.S.I. @ 60°F.
	5250/5835 P.S.I. @ 160°F.

**OPERATING PROCEDURE**

1. Connect the pressure hose from the hydraulic system being tested to the "INLET" port of the hydraulic tester.
2. Connect the return hose to the "OUTLET" port of the hydraulic tester. It may be connected in series.
3. The pressure gauge in this hydraulic tester should not be subjected to sudden surge or shock loads. Any pressure applied to a hydraulic system being tested must be obtained by operating the hydraulic tester restrictor valve.

**IMPORTANT: Open restrictor valve before and after each individual application of pressure.**

4. After oil is flowing through the hydraulic tester, gradually increase the pressure to the desired setting.
5. This hydraulic tester will measure pressures up to 5,000 PSI (345 BAR). If the system being tested has no safety valve in the line and cannot withstand 5,000 PSI (345 BAR), the restrictor valve **MUST** be open when starting the test and the maximum pressure must be controlled by the operator.

When performing a direct pump test (as shown in Figure 3) NEVER increase the pressure beyond the system's maximum relief valve setting or serious damage to the pump under test may result! Remember...during a direct pump test, the relief valve has been completely by-passed and it no longer protects the pump from excessive pressure. Refer to equipment manufacturer's specifications for maximum relief valve pressure...DO NOT permit reading on tester's high pressure gauge to exceed that pressure! **Before testing the system, always open the pressure control valve by turning the valve handle counterclockwise.**

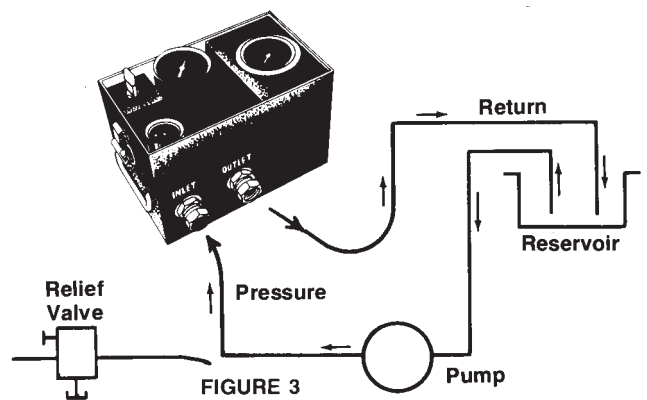

When testing a system's relief valve, refer to the equipment manufacturer's service manual to determine the relief valve setting. Turn the hydraulic tester's pressure control valve knob clockwise until the proper relief valve setting has been reached.

**NOTE: The relief valve setting is easily recognized...the pressure gauge needle will fluctuate, indicating unloading or by-passing of oil over the relief valve, and the GPM indicator will show a decrease in flow through the tester, indicating that the balance of pump output is going through the relief valve. Then, to obtain an accurate flow reading, turn the pressure control valve knob counterclockwise until the pressure level is SLIGHTLY under the relief valve setting.**

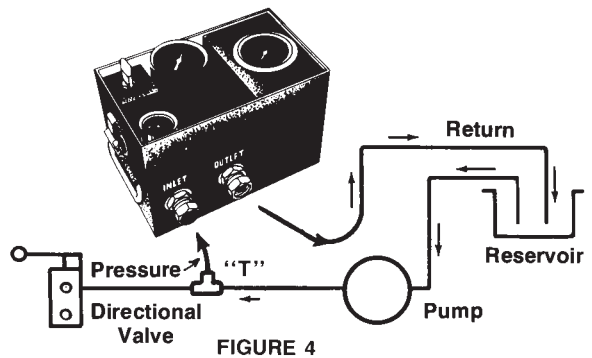

Connect the inlet port of the hydraulic tester to a "T" connection installed between the pump and the directional control valve (see Figure 4). Connect the outlet port of the tester to the reservoir. Refer to manufacturer's specifications for the test information.

## A TYPICAL TESTING PROCEDURE:

The following example will illustrate how this hydraulic tester is used to locate a hydraulic system malfunction. The hydraulic system illustrated below consists of a reservoir, a pump, a relief valve, a directional control valve and a double-acting cylinder. The problem: the cylinder's piston moves out at almost normal speed under no load, but gradually slows down as the load increases. The trouble can lie anywhere in the system. First, all hoses and connections should be checked for leakage, and if the trouble does not lie there, the hydraulic tester should be used to check each of the system's components for efficiency.

### DIAGRAM 1 -- TESTING HYDRAULIC PUMP

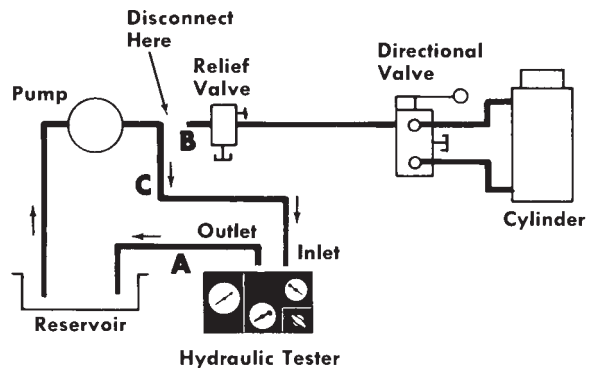

TESTING THE PUMP . . . Step 1. See Diagram 1. Connect line (A) between hydraulic tester's outlet port and system's reservoir. This connection can be maintained until all testing is completed. Step 2. Disconnect line (B) between pump and relief valve. Connect line (C) between discharge port of pump and hydraulic tester's inlet port. Next, **open pressure control valve of hydraulic tester by turning knob counterclockwise**. Turn pulsation dampener knob counterclockwise several turns. Start pump. Set engine RPM for rated speed of pump (Equipment manufacturer's specified RPM level for a given rate of flow). If the action of the gauges is erratic and severe pulsation occurs, even after the dampener knob has been adjusted, cavitation of the pump may be indicated. . . Pressure readings are made from tester's pressure gauge. When normal operating temperature is reached, open pressure control valve by turning knob counterclockwise and refer to flow-meter gauge, recording volume at low pressure. Increase pressure by turning knob clockwise, and record volume at increments up to maximum pressure. Open pressure control valve and shut off pump. Now, check results against manufacturer's recommended ratings. If results are low, the trouble is in the pump, suction line or filter. If results check, the trouble is beyond the pump, and we must next check the relief valve. Disconnect line (C) between hydraulic tester's inlet port and discharge port of pump. Reconnect line (B) between pump and relief valve.

### DIAGRAM 2 -- TESTING RELIEF VALVE

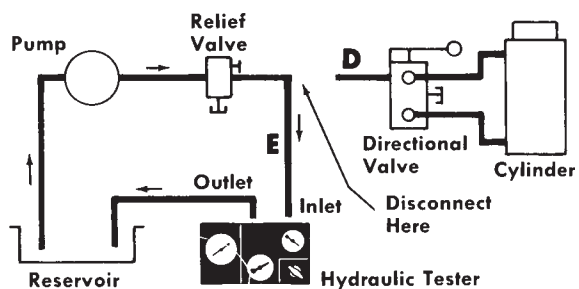

TESTING THE RELIEF VALVE . . . See Diagram 2. Disconnect line (D) between relief valve and directional valve, and connect line (E) between relief valve and tester's inlet port. **Open pressure control valve**. Turn dampener temperature has been reached, record volume and pressure at various increments to maximum pressure. The pressure at which the flow falls off to 0 is the relief pressure. If this pressure is below maximum operating pressure, the relief valve should be adjusted. Up to relief pressure, flow should be the same as that of the pump. If it is not, this is an indication that the relief valve is leaking and should be repaired. If the trouble does not lie in the relief valve, the directional valve must be tested next. Disconnect line (E) between relief valve and hydraulic tester's inlet port. Reconnect line (D) between relief valve and directional valve.

## DIAGRAM 3 -- TESTING DIRECTIONAL VALVE

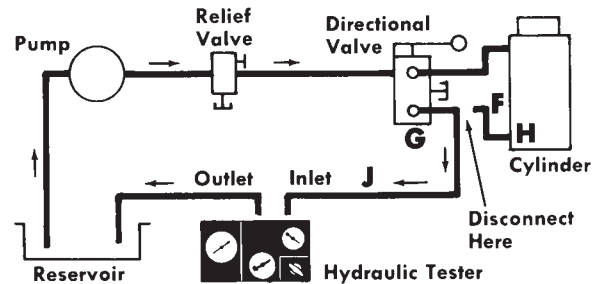

TESTING THE DIRECTIONAL VALVE . . . See Diagram 3. Disconnect line (F) between cylinder port (G) of directional valve and pressure end (H) of cylinder. Connect line (J) between cylinder port (G) of directional valve and hydraulic tester's inlet port. **Open pressure control valve.** Turn dampener knob counterclockwise several turns. Start pump, set engine RPM for rated speed of pump. After operating temperature has been reached, shift directional valve to direct oil from cylinder port (G) of directional valve to hydraulic tester's inlet port. Record pressure and volume at various increments as was done in testing the pump and relief valve. If full volume and pressure cannot be obtained, the directional valve is the cause of trouble, and must be repaired or replaced. If full rated volume at full pressure is recorded, however, the trouble is in the cylinder.

## DIAGRAM 4 -- TESTING WITH A "T" CONNECTION

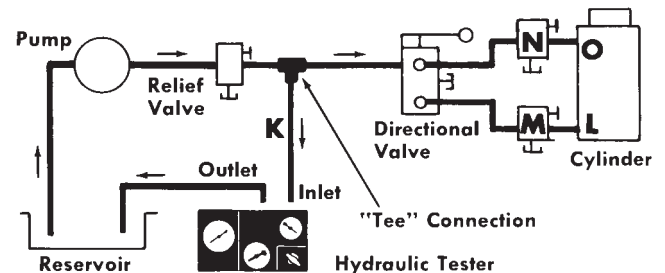

## TESTING WITH A "T" CONNECTION...

The above diagram illustrates a method of testing overall-circuit performance. Connect line (K) from hydraulic tester's inlet port to a "T" connection in the circuit, as shown. **Open tester's pressure control valve.** Turn dampener knob counterclockwise several turns. Start pump, set engine RPM for rated speed of pump. After operating temperature has been reached, shift directional control valve to direct oil through relief valve (M), to cylinder port (L). Close tester's pressure control valve partially to allow cylinder to extend and "dead-end."\* Oil will flow to reservoir either through the hydraulic tester or through leaks in components of the circuit. Read flow at no load. Increase load on circuit by slowly closing the tester's pressure control valve and read flow at a pressure slightly below the relief valve setting. The difference in readings indicates oil lost because of leaks somewhere in the circuit. Continue to increase load until the indicated flow drops drastically, and take pressure reading. . . this reading indicates setting of relief valve (M). To obtain setting of relief valve (N), shift directional control valve to direct oil to cylinder port (O) and repeat procedure described above. To isolate the defective component, tests as described in Diagrams 1, 2 and 3 should be used.

\*If design characteristics of the cylinder make a "dead-end" inadvisable, simply plug the end of the line leading to the cylinder.