



SPX
 655 Eisenhower Drive
 Owatonna, MN 55060-0995 USA
 Phone: (507) 455-7000
 Tech. Serv.: (800) 533-6127
 Fax: (800) 955-8329
 Order Entry: (800) 533-6127
 Fax: (800) 283-8665
 International Sales: (507) 455-7223
 Fax: (507) 455-7063

**Parts List &
 Assembly Instructions**
 for:

5090

© SPX

Back Buddy™ II

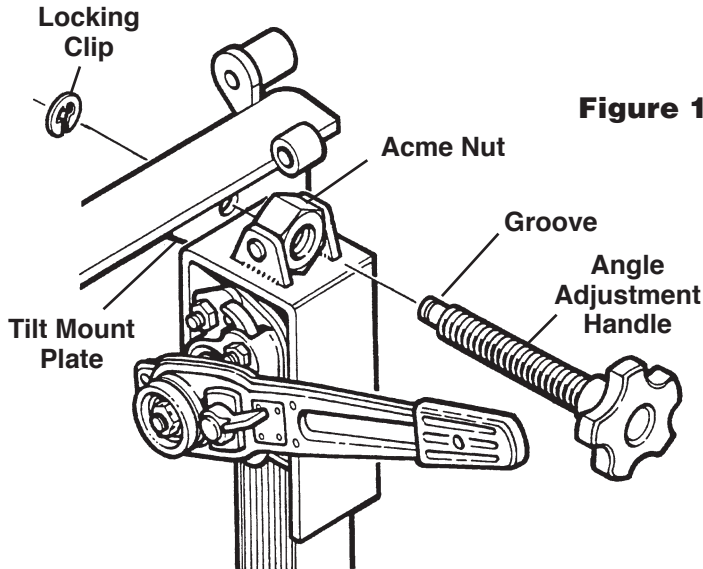

Figure 1

Assembly

The quantity of each part is identified in parenthesis on the illustration. Parts not identified with a number are single unit parts.

Attach the Angle Adjustment Handle

1. Thread the angle adjustment handle through the acme nut as shown in Figure 1. Insert the shaft end of the angle adjustment handle through the tilt mount plate.
2. Press the locking clip into the groove of the angle adjustment handle.
3. Align the hinge connectors of the upper grab bar with the hinge connectors of the main frame assembly as shown in Figure 2. Secure the grab bar in place using two hex head bolts (3/8" x 2"), two washers (3/8"), and two locknuts (3/8").
4. Thread a pop pin into each side of the main frame assembly as shown in Figure 3.

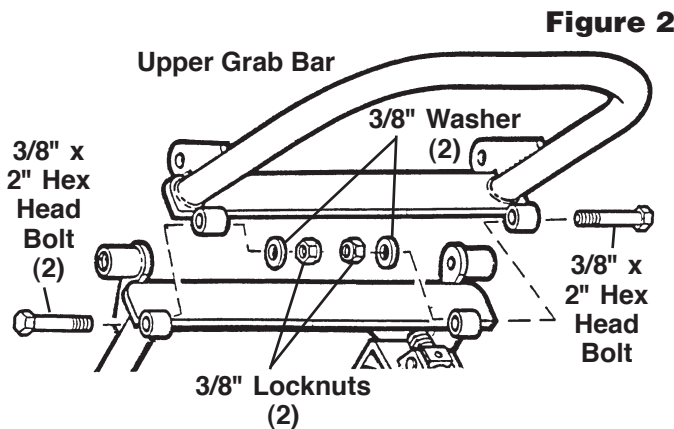

Figure 2

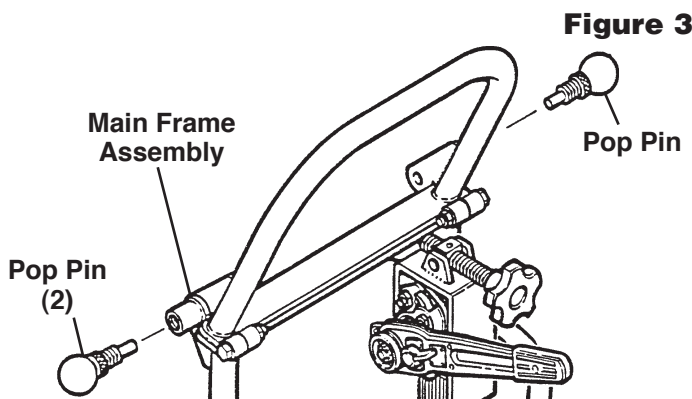
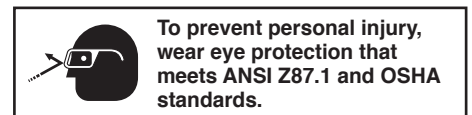

Figure 3

Back Buddy is a trademark of TSI.



Assembly contd.

5. Position the U-frame assembly into the tabs of the slider portion of the main frame assembly as shown in Figure 4, and secure the assembly in place using two hex head bolts (1/2" x 3.5") and two locknuts (1/2").

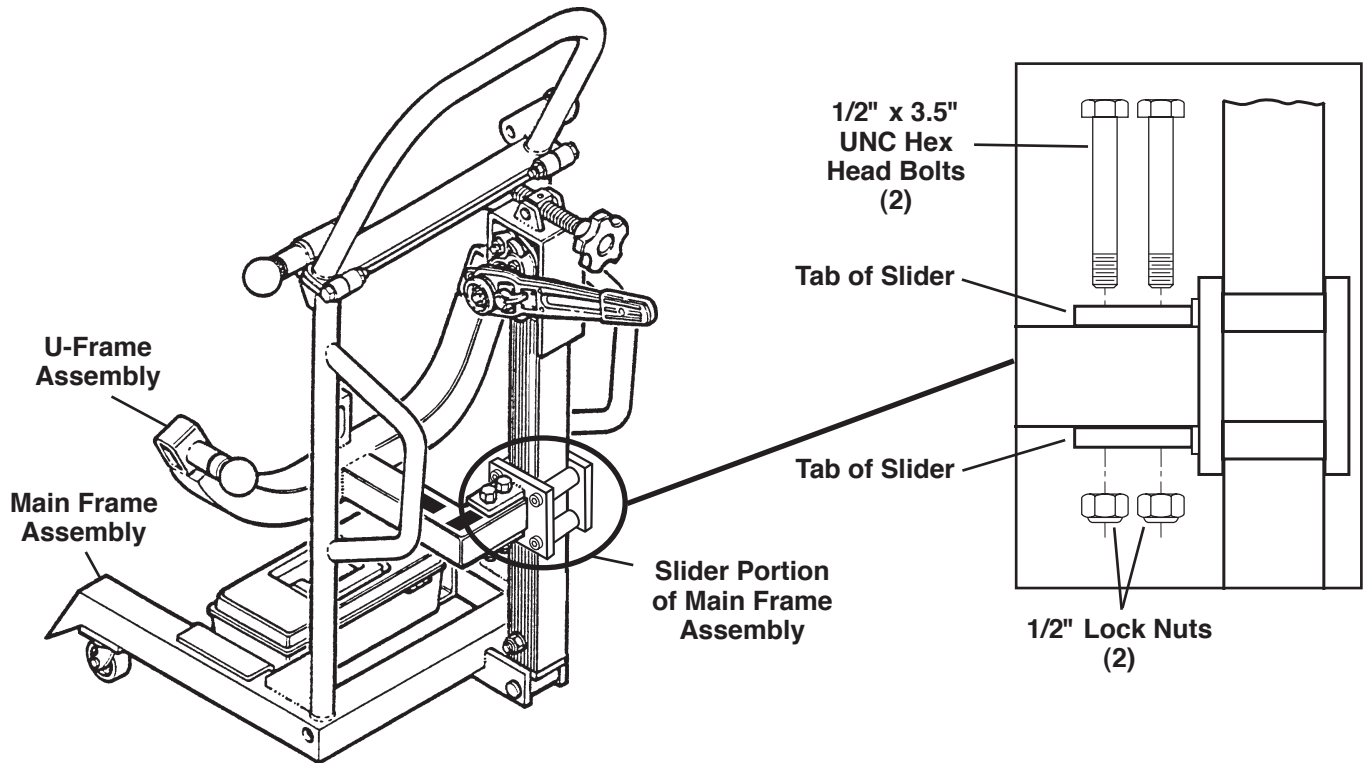

Figure 4

6. Slide the axle shaft into the main frame assembly as shown in Figure 5. Install a wheel onto each end of the axle shaft.

Note: The valve stem should be positioned to the outside of the tire.

Insert cotter pins into the holes in each end of the axle shaft, and bend the ends to secure the wheels in place.

Inflate tires to 50 PSI.

7. Place the oil catch pan between the tabs on the U-frame assembly.

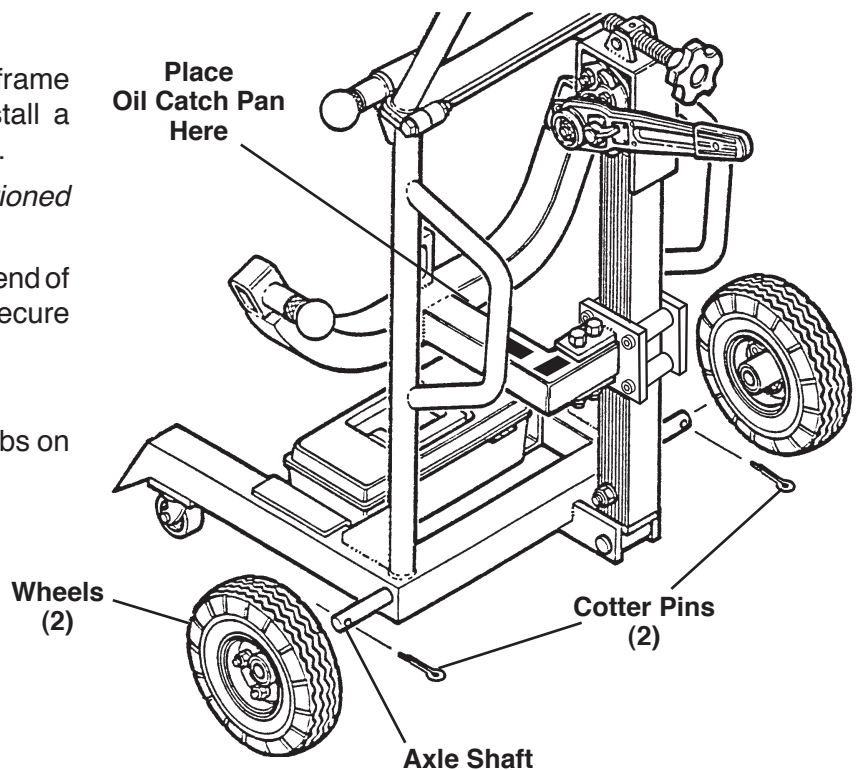
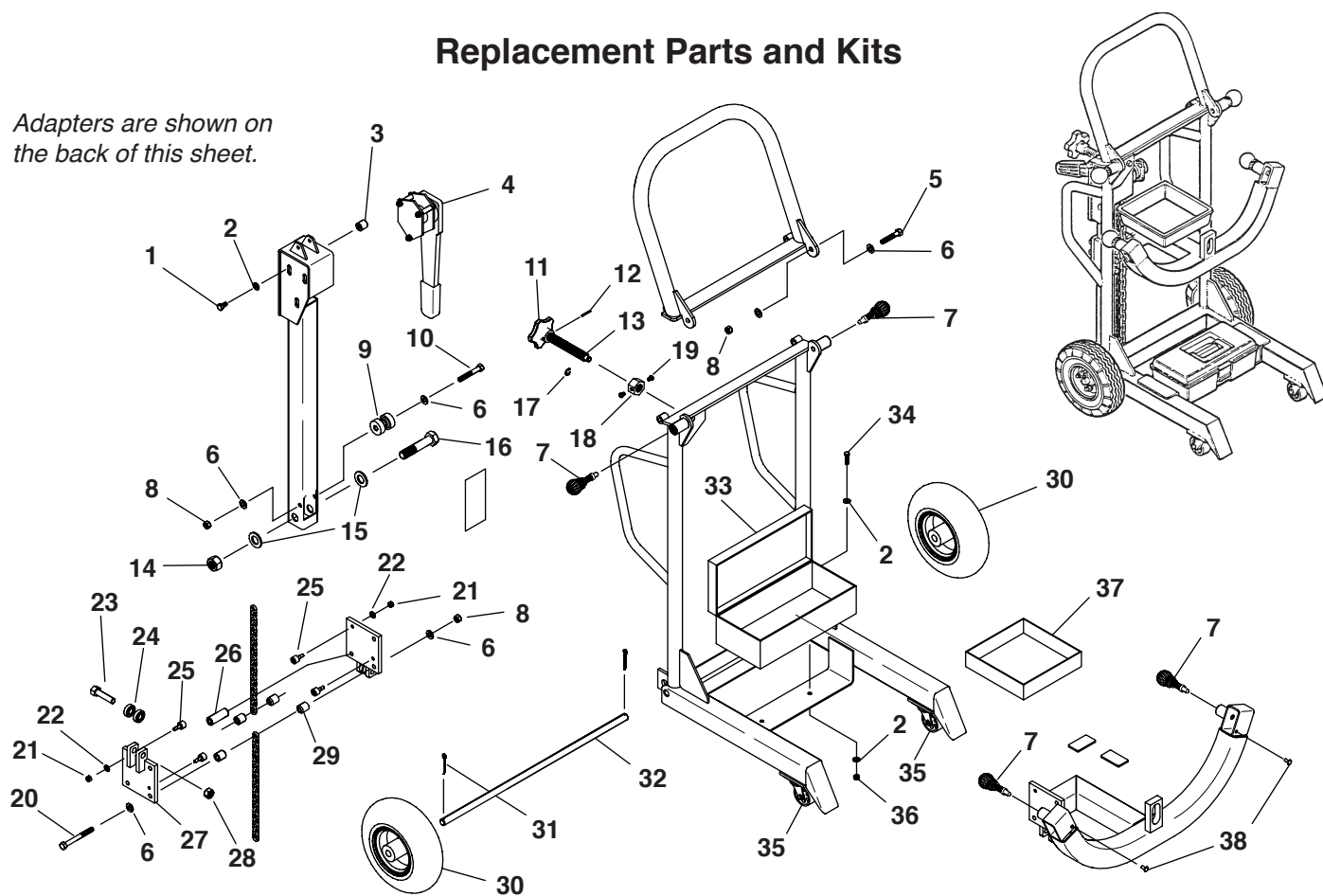

Figure 5

Replacement Parts and Kits

Adapters are shown on the back of this sheet.



No. 513919 Tilt Adjustment Kit

Item	Qty.	Description
11	1	Handle
12	1	Spring Pin (1/8 x 1)
13	1	Screw (3/4-6)
17	1	E-ring (external)
18	1	Tilt Screw Nut
19	2	Screw

No. 513923 Tool Box Kit

Item	Qty.	Description
2	4	Washer (1/4)
33	1	Tool Box
34	2	Cap Screw (1/4-20 x 1)
36	2	Hex Nut (1/4-20)

No. 513924 Hoist Kit

Item	Qty.	Description
1	3	Cap Screw (8 mm x 5/8)
2	3	Washer (1/4)
3	3	Spacer (8 mm x 1.25)
4	1	Ratchet Winch

No. 514027 Axle Kit

Item	Qty.	Description
31	2	Cotter Pin (1/8 x 1-1/4)
32	1	Axle Shaft

No. 549116 Cam Follower Kit

Item	Qty.	Description
21	1	Hex Nut (1/4-28)
22	1	Lockwasher (1/4)
25	1	Cam Follower (1/4-28)

No. 549117 Slider Plate Kit

Item	Qty.	Description
6	6	Washer (3/8)
8	3	Hex Nut (3/8-16)
20	3	Cap Screw (3/8-16 x 3-1/2)
21	4	Hex Nut (1/4-28)
22	4	Lockwasher (1/4)
25	4	Cam Follower (1/4-28)
26	1	Slider Box Roller (lg.)
27	1	Slider Plate
29	4	Slider Box Roller (short)

No. 549118 Hardware Kit

Item	Qty.	Description
1	3	Cap Screw (8 mm x 5/8)
2	3	Washer (1/4)
3	3	Spacer (8 mm x 1.25)
5	2	Cap Screw (3/8-16 x 2)
6	4	Washer (3/8)
8	3	Hex Nut (3/8-16)
9	1	Roller Chain Guide
10	1	Cap Screw (3/8-16 x 2-1/2)
14	1	Hex Nut (3/4-10)
15	2	Washer (3/4)
16	1	Cap Screw (3/4-10 x 3-1/2)
23	2	Cap Screw (1/2-13 x 2)
24	4	Ball Bearing
28	2	Hex Nut (1/2-13)
38	2	Rivet

Replacement Parts

Item	Part No.	Qty.	Description
7	513920	4	Pop Pin
30	513916	2	Wheel / Tire Assy
35	513915	2	Caster
37	513914	1	Oil Drip Pan
	514019	1	Logo Decal

Installation of Universal Receiver and Adapter Sets

Universal receiver and adapter sets enable the Back Buddy™ to work with almost all hub and drum assemblies. With a simple change of adapters, the Back Buddy goes from an inboard hub / drum lifting device to an outboard drum or spoke lifting device – in seconds!

Changing adapters is as easy as pulling out a spring-loaded locator pin and inserting the adapter, as shown in Figure 6.

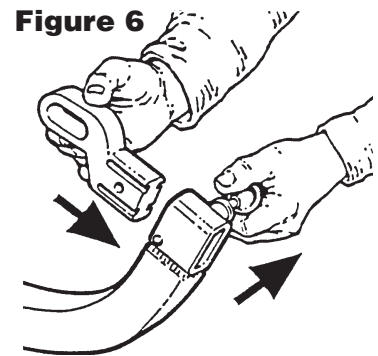

Styles of Adapters

No. 513925 for 5-Spoke

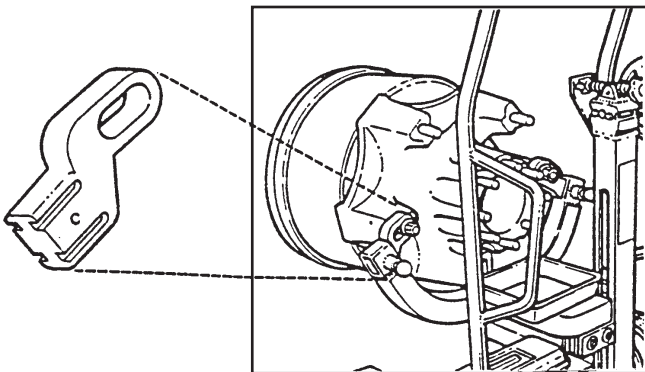

No. 513925 for 6-Spoke

Invert 5-spoke adapter (513925) for use on 6-spoke hub and drum.

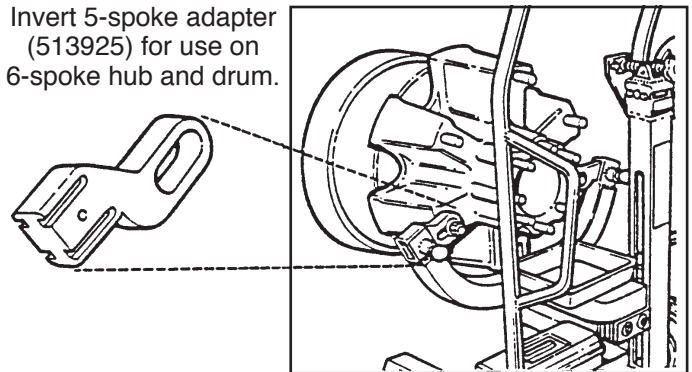

No. 513926 for 10-Hole Inboard

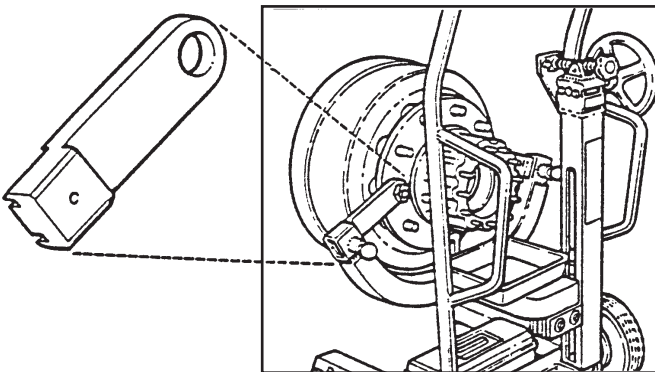

No. 513927 for 10-Hole Outboard

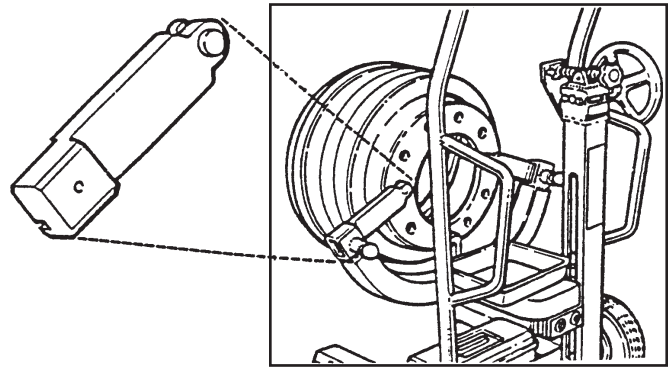

Additional Adapters Available

- 514642** – Interchangeable left or right. Adapters connect directly to studs, 10 stud inboard hubs. Studs 335 mm on center.
- 514643** – One right and one left. Adapters connect directly to brake drum, 10 stud outboard hubs. Studs 11.25" on center, 3/4" hub back plate thickness.
- 514644** – One right and one left. Adapters connect directly to studs, 8 stud inboard hubs. Studs 275 mm on center.
- 514645** – One right and one left. Adapters connect directly to brake drum, 8 stud outboard drums. Studs 275 mm on center, 1/2" hub back plate thickness.
- 514646** – One right and one left. Adapters connect directly to studs, 6 stud inboard hubs. Studs 8-3/4" on center.
- 514647** – One right and one left. Adapters connect directly to brake drum, 6 hole outboard drums. Studs 8-3/4" on center, 1/2" hub back plate thickness.
- 514648** – Only one required. Adapter connects directly to studs, 8 stud inboard hubs. Studs 6-1/2" on center Hummer/ Humvee geared hubs.