

# MUSCLE TOOLS

Electronic Diagnostics | Special Tools | Shop Equipment | A/C Tools

Q3 2014 Edition



## BL8992K Special 30th Anniversary Bundle

- Includes:**
- Brake Lathe 8922
  - Bench
  - 3-Jaw Chuck
  - Micrometers

**MSRP \$7,995**

- Celebrating 30 years of the original Accu-turn single pass lathe that changed the industry
- Solid 470 lbs metal casting absorbs vibration for added rigidity
- Exceeds OE specifications with a "one pass" finish, regardless of the depth of cut
- Designed by a machinist for a true machine shop finish utilizing extra-large dovetail ways and adjustable gibbs
- Designed for maximum longevity and performance
- A must have in any shop performing brake jobs!
- Still made in the USA



## Wheel Service Rebates:

### Gift Card Rebates:

- \$500 TCE 4230, TCE 4230SFA, WBE 4230
- \$650 TCE 4335
- \$1500 FWA 4437, FWA 4630



Visit [www.Boschrebates.com](http://www.Boschrebates.com) to redeem. Available in US and Canada.

Extended to Dec. 31, 2014

## COMING SOON: AUGUST Encore TPR & Heavy Duty

The 3834T TPR Bluetooth wireless TPMS sensor ID transfer to Encore speeds TPMS registration and eliminates manual entry typos!  
Heavy Duty Standard 3895-07 kit adds enables an Aftermarket Repair shop to diagnose Light, Medium and Heavy Duty vehicles.



3834T

3895-07

## COMING SOON AUGUST 30 Bosch ESI[truck]

- "All makes" coverage – Including Cummins and Volvo
- Key parameter resets, reprogramming and calibrations
- Key special tests (Cylinder cut-out, actuations, others)
- Wiring diagrams, sensor locations and repair tips



3824

## COMING SOON MID JULY Battery Testing With Your Smart Device

### OTC Smart Battery Tester tests batteries, starting and charging systems with smart device

Download the OTC3200 app from the Google Play or iTunes store. View battery test data by scanning the device QR code\*. Instructions included on testing device.

- All light duty applications - test 6V, 8V and 12V lead acid and AGM batteries.
- Diagnose bad batteries faster – an internal 9V battery allows for deeply discharged batteries, reducing the charge and retest result.
- Share your test results – print, save or email a customer friendly color report.
- Confidently recommend repairs – use your smart phone or tablet camera to embed photos into customer reports.



3200

\*Smart devices paired with the tester must have auto-focusing rear-facing camera to meet full requirements.

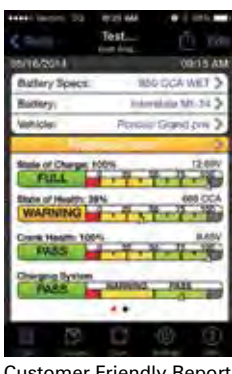

Customer Friendly Report



Technician Detail Report



**Purchase a new Robinair A/C Cart (34288, 34788, 34788H or 34988) from your local distributor and receive a free A/C Leak Detector Kit (16235)**



Visit [www.robinair.com](http://www.robinair.com) to redeem and see complete program details. Valid March 1 – September 30, 2014.

## Your one stop shop for OEM tools Bosch brings authentic OEM diagnostics to aftermarket

Learn more on page 2



## NEW 1060-HYD OTC 10 Ton Hydraulic Puller Kit

The OTC 1060-HYD delivers 10 tons of force for industrial bearing service.

Learn more on page 4



## WHAT'S NEW AT OTC & ROBINAIR

OTC launches new blog: Technicians Corner

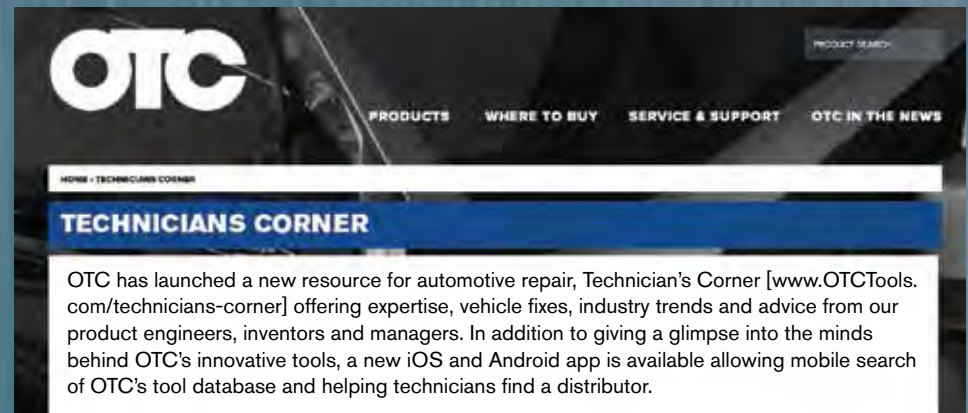

Robinair launches new website



Robinair.com relaunches this month, featuring a updated product categorizations, a new technician's blog and a new maps feature making it easier to find a distributor, reseller or retailer.

Coming soon, the Robinair Catalog App...stay tuned for details!

OTC kicks off bike build with Bryan Fuller

Join OTC as we create a one-of-a-kind bike with Fuller Hot Rods. Watch the amazing transformation of a Triumph Speed Triple into the OTC Triple Speed. It all starts now!



**\$200 or \$325 REBATE**  
On GENISYS EVO®

**PURCHASE A QUALIFYING GENISYS EVO AND RECEIVE A GIFT CARD**

GENISYS EVO MODEL GIFT CARD VALUE  
3874, 3874HD, 3874TPR, 3874MVC1 . . . . . \$325  
3875 . . . . . \$200

**HOW TO PARTICIPATE**

1. REGISTER ON [WWW.BOSCHREBATES.COM](http://WWW.BOSCHREBATES.COM)
  2. PROVIDE A VALID SERIAL NUMBER
- Expires December 31, 2014.



**Genisys Touch™ Trade Up Promotion**

Expires December 31, 2014

Replace your old professional scan tool\* with the Genisys Touch and choose from a OTC Tech Scope or OTC TPR Tool.

Details can be found at [www.otctools.com](http://www.otctools.com)  
Participate by visiting [www.boschrebates.com](http://www.boschrebates.com)

\*Code readers do not qualify.



3857 Tech Scope (value \$1099) or 3834T TPR (value \$459)

**Your one stop shop for OEM tools**

**Bosch Tech 2 \$700 Rebate**

The only authentic General Motors Tech 2 scan tool with full, dealer-level diagnostics. Includes preloaded software that doesn't expire.

Visit [boschrebates.com](http://boschrebates.com)



**F00E900977**

Tech 2 Pro Optima

Expires December 31, 2014

**Bosch brings authentic OEM diagnostics to aftermarket again with Ford VCM II**

F00E9016307HH



**The Ford Vehicle Communication Module II (VCM II)**

- Authentic OEM diagnostics for Ford, Lincoln and Mercury Vehicles.
- Customer Flight Recorder (CFR) functionality with an optional pendant cable.
- Four LED indicators and signaling device providing technician with continuous visual as well as audible operating status.
- Enhanced 802.11 wireless that minimizes dependencies on service department wireless capability infrastructure.

**F00E9016297HH\***

Includes VCM II, VCM to Laptop cable, USB wireless cards, and DLC cable.

**F00E9016307HH\***

Includes all contents of F00E9016297HH plus CFR kit.

\*Software license sold separately.

Ford and VCM II are used under license from Ford Motor Company.

**3112**

**Battery Reset Tool**

The 3112 Battery Reset Tool has the latest software to work on today's vehicles where a battery reset procedure is required.

- For use with:
  - Late Model BMW
  - Late Model Mini Cooper
  - Late Model Ford F-Series Trucks
- Updateable
- AutoID™ – Automatically pulls Make/Model/Year/Engine for most vehicles
- Trilingual Menu – English, Spanish and French
- Upgrade software Compatible with Windows XP, Vista, 7, and 8.
- Compatible with 32 and 64-bit OS.



**F00K108322**

**GM MDI**

- Authentic General Motors MDI vehicle communication interface (VCI) for wireless J2534 reprogramming and diagnostics.
- Requires software subscription to GM SPS (Service Programming System), which must be purchased separately via the ACDelco Tech Connect website.



**F00E901631**

**Bosch Mastertech VCI**

**Validated J2534 Flashing** – covers GM, Ford, Chrysler, Honda, Nissan, Mazda, Mitsubishi, Saab, BMW, and more to come. M-VCI is an OEM approved reprogramming device.

**Authentic OEM Dealer Level Diagnostics\*** – compatible with BMW ISTA, Saab GDS 2, GM Tech2Win, GM GDS 2, and more to come.

**F00E901632 Bosch Mastertech VCI Aftermarket Diagnostic Software** – Includes the final release of Shop Foremen Pro and ESI 2.0.

\* OEM dealer diagnostic software is purchased separately from vehicle OEM websites.



**3880X**

**OTC Automotive Inspection Camera**

- Large 3.5" inch high resolution color screen for optimal viewing.
- Detachable 36" camera snake with position hold shaft.
- Images and video are recorded on the included SD card and can be viewed on the camera display or transferred to a computer.

**PROFESSIONAL SCAN COMPARISON**



Scan Functionality	Genisys EVO 3874TPR	Encore 3893	Genisys Touch 3895
OEM Domestic/Asian/European Bidirectional Controls	•	•	•
OEM Domestic/Asian/European OBD II Enhanced	•	•	•
OEM Domestic/Asian/European OBD I	•	•	•
All 10 Modes of OBD II	•	•	•
Heavy Duty Standard Coverage	Option	Option	Option
Multiple Language Support	•	•	•
Internet Upgradeable	PC Required	•	•
J2534 All Makes Reprogramming	•	•	•
<b>Vehicle Diagnostic Software Information</b>			
Scan and Scope Troubleshooting Repair Information	•	•	•
Repair-Trac & Code-Assist DTC VIN Specific Tech Tips	•	•	•
Symptom-Assist Specific Tech Tips	•	•	•
Identifix Direc based Info	•	•	•
AutoDetect™	•	•	•
AutoID™	•	•	•
Embedded Training Videos	•	•	•
<b>Hardware</b>			
Battery Power	•	•	•
WiFi Wireless	•	•	•
Bluetooth Long Range Wireless	TPR Tool Wireless	•	•
Headphone Jack	•	•	•
High Resolution Touch Screen Display	•	7" Capacitive	10" Resistive
VGA Video Out	•	•	•
Stereo Speakers	•	•	•
Wireless to the car VCI	•	•	•
<b>Diagnostic Accessories</b>			
High Speed Scope	Option	Option	Option
Bluetooth Wireless TPMS Sensor Reprogramming	Option	Option	Option
5-Gas Analyzer	Option	•	•
<b>Software</b>			
Operating System	Lynx	Android	Windows 7
Internet Browser	•	•	•



**3415**

**OTC CAN Test Box**

**Breakout Box for Scan Tools**

- Connects between Diagnostic Link Connector (DLC).
- Connect leads for increased diagnosis, analysis, and monitoring.

**Useful Functions**

- LEDs display signal detection
  - Flashing LEDs indicate ECU activity.
- Magnifies DLC
  - Allows monitoring of OBD II data lines.
- Monitors voltage
  - Displays battery voltage.
  - Alarm warning when voltage drops below 11.6v or rises above 15v.



**3895**

**Genisys Touch™ Deluxe Kit**

Includes a ruggedized 10" high resolution display tablet, J2534-1 / -2 compliant Vehicle Communications Interface (VCI), 10 OEM adapters, OBD II cable, USB cable, 12V power cable, AC power supply and custom carrying case.

**OTC Leak Tamer 30-Day Satisfaction Guarantee**

It's a straight forward guarantee. Buy it, try it for 30 days, if you don't find that it helps you get your job done you can return it to your participating authorized dealer and get your money back.



**6522**

**OTC EVAP – Leak Detection System**

- Pinpoint leaks with Smoke and dye
  - UltraTraceUV® dye deposits at exact location of a leak
  - Finds leaks that smoke alone won't find
  - It's the only OEM-Approved dye solution
- Compact light weight design
  - More powerful diagnostics in smaller package

**3076**

**OTC HD Scan with Ez-Tap**

- In-shop wireless capability.
- Ez-Tap Wireless Vehicle Communication Interface (VCI) works with OEM diagnostic software.
- One wireless VCI for all your diagnostic software.
- Eliminate cables and cable replacement costs.



### Genisys EVO® Software

**3421-146**

#### 2013 Super Bundle Kit

- Everything needed to update a Genisys
- Includes 2013 Domestic/Asian, 2012 European, and preloaded System 5.0 memory card



**3421-147**

#### 2013 Software Loyalty Kit

- Designed for customers already have System 5.0
- Includes 2013 Domestic/Asian and 2012 European



**3421-148**

#### 2013 System 5.0 4GB Memory Expansion Kit

- Pre-loaded with 2013 application software
- New applications require a separate purchase



### Nemisys Software

**3774-37**

#### OTC Nemisys 2013 Domestic/Asian software

OEM based 2013 Domestic and Asian coverage back to 1983 for engine, body, and chassis systems. Includes the Code-Assist™ Library of experienced-based Confirmed Fixes™ from Identifix® and Data / Sensor Info repair information.



### Encore/Genisys Touch HD

**3895-07**

#### OTC Heavy-Duty Standard

- Class 4 - 8 Heavy Duty Standard truck Coverage
- Read / erase codes and view live engine data



### Heavy Duty Truck

**3940-HD**

#### OTC DMM Kit for HD Truck

Professional grade multimeter kit for heavy duty truck repair

#### OTC 550 Series Auto Ranging Multimeter

- Powerful professional grade test functions:
- Frequency
  - Duty Cycle
  - Diode & Continuity Tests

#### Mid-Range Amp Probe

- Non-intrusive AC/DC current measurement
- Measurement range of 2-600 amps AC/DC
- Covers HD truck components and electric motors

#### Extended Length Test Leads

- 5 ft. test leads to provide improved reach
- Detachable probes allow use with amp probe

### Hybrid Multimeter

**F00E900101**

#### Bosch MMD 540H Hybrid Multimeter

The Bosch MMD 540H Hybrid Multimeter is a CAT safety rated, auto ranging digital multimeter designed for use in diagnostics of electronic circuits. Whatever your shop services: automotive, fleet, motorcycle, marine or small engine, the MMD 540H has the capability to keep up with your business.

- CAT III (1000v) safety rating for hybrid vehicle circuits.
- Peak, Min/Max readings as fast as 1 millisecond.
- Higher amperage test ranges, up to 20 Amps.
- Inductive RPM clamp for conventional and DIS ignition systems.
- Fused diagnostic test leads for safe trouble shooting (up to 20 amps) at the circuit fuse location.
- K-Type thermocouple for quick temperature measurement.
- Large LCD display with bright back lighting and auto shutdown.



**3111PRO**

#### OTC Trilingual Scan Tool OBD II, CAN, ABS & Airbag

**Fix it Faster!** Expanded Domestic and Asian ABS & Airbag coverage. Now with over 4.3 million verified fixes at the touch of a button! Compatible with all 1996 and newer cars and light trucks.

#### Airbag (SRS) & ABS coverage:

1996-2010 GM, Ford and Chrysler  
1996-2009 Toyota, Honda, Hyundai and Nissan.

**Enhanced code request** For GM, Ford, Chrysler, Honda, Hyundai, Nissan and Toyota vehicles.

**Displays additional live engine data:** Now over 300+ possible PIDs. View engine RPMs, coolant temperature, Oxygen sensor readings and more!

**AutoID™** Automatically retrieves VIN from vehicle and decodes to Year/Make/Model.

**Component Locator** Text descriptions indicate where the vehicle component is located.

**3108N**

#### OTC Pocketscan® Code Reader

- View LIVE engine data.
- Automatically reads DTC's.
- Erases DTCs.
- Reads and displays MIL status.
- Reads and displays I/M monitors.



**3109N**

#### OTC Trilingual OBD II/EOBD and CAN Scan Tool

- AutoID™ - Automatically selects the vehicle so you don't have to on most 2000 and newer vehicles.
- Graph live data.
- Read and erase diagnostic trouble codes.
- Read and display LIVE sensor data.
- Read and display freeze frame data.



### Battery

**3167**

#### OTC Battery and Electrical System Diagnostic Tester

- Digital circuitry precisely controls battery test loads to accurately determine battery conditions.
- Tests both flooded lead acid and AGM/gel cell batteries accurately—down to 1 volt state of charge.
- Tests vehicle starting and charging systems with minimal user interaction.
- Tests all 6- & 12-volt batteries with a 50-2000 CCA operating range.
- Scales: CCA, CA, AHR, MCA, JIS, DIN.
- Removable/ auto-sensing 3' leads.



**3183**

#### OTC Digital Battery Tester

Speed. Accuracy. Reliability. These are the cornerstones behind the technology in our digital battery testers. No. 3183 tests 12-volt batteries (125-1400 CCAs) and analyzes by measuring multiple parameters within the battery to deliver accurate results. A live voltmeter allows easy starting/charging system testing. Its bright, 4-digit LED display indicates the battery's good/bad status, voltage, and available CCAs. It even compensates for cold temperatures.



**0684400732**

#### Bosch BAT 131 - Battery & Starting/Charging System Tester

The BAT 131 is the benchmark in battery testing, and is designed for testing all types of 6V and 12V starter batteries, including lead-acid, gel and fleece batteries/AGM. The rugged, exterior housing is specially designed to survive the harshest workshop conditions and molded perfectly for one-handed operation.

The load free test procedure provides fast, precise and reliable measurement results between 100 and 2000 CCA. In addition to CCA, the BAT 131 can also measure and display to CA, MCA, DIN, SAE, EN, IEC and JIS standards.



## Engine Tools

**6690**

#### Ford Master Cam Tool Kit

- Contains 40 tools to ensure correct cam timing when servicing timing belts, chains, head gaskets, or other valve train repairs.
- Covers L4, V6, V8, V10 engine with 2V, 3V, 4V valve configurations, model years 1991 - Present.
- Application guide with diagrams and blow molded case included.



**6690-1**

#### Ford Cam Tool Kit Update

- Contains 18 tools, with case locations for addition of the popular 6489 Ford Cam Tools, making a 6690 Kit.
- Ford Cam Tools ensure correct cam timing when servicing timing belts, chains, head gaskets, or other valve train repairs.
- 6690-1 tools cover L4, V6, V8, V10 engines with 3V & 4V valve configurations, model years 2004 - Present.
- Application guide with diagrams and blow molded case included.



**6680**

#### Ford 3.9L 4V Cam Tool Set

- The 6680 is designed to service Ford 3.9L 4V V8 engines used in 2000-2006 Lincoln LS cars.



**6682**

#### Ford 3.5L & 3.7L 4V Cam Tool Set

- Ford 3.5L 4V V6 engines used in 07-12 Edge & MKZ, 07-09 MKX, 08-12 Taurus & Taurus X & Sable, 10-12 Fusion, 10-12 MKZ & MKS & MKT, 11-12 Explorer & F150.
- Ford 3.7L 4V V6 engines used in 09-12 MKS, 10-12 MKT, 11-12 Mustang & F150 & MKZ & Edge.



**6486A**

#### Ford 2.0L, 2.3L, 2.5L 4V Cam Tool Set

- Ford 2.0L 4V L4 engines used in 94-12 multiple vehicle platforms.
- Ford 2.3L 4V L4 engines used in 05-08 Escape Hybrid, Mariner Hybrid.
- Ford 2.5L 4V L4 engines used in 09-12 Escape & Mariner, 10-12 Fusion & Fusion Hybrid, 11-12 MKZ.



**6678**

#### Cam Gear Holder, 2 pack

- The holders clamp between the engine block or head and the back of the gear to lock it in place.
- Use on single, dual, or quad cam engines to hold valve timing during belt replacement.
- Excellent for diesel injection pump belt replacement.
- The cam gear holders universal design are quick and easy to install.



**6679**

#### Cam Gear Clamp & Holder Set

- The holders clamp between the engine block or head and the back of the gear to lock it in place. The cam gear clamp is used between two adjacent gears to lock them together and eliminate movement.
- Use on single, dual, or quad cam engines to hold valve timing during belt replacement.
- Excellent for diesel injection pump belt replacement.

**6681**

#### Ford 4.6L, 5.4L, 6.8L 3V Cam Tool Set

- The 6681 is designed to service;
- Ford 4.6L 3V V8 engines used in 05-10 Mustang, 06-10 Explorer, 09 F-Series trucks.
- Ford 5.4L 3V V8 engines used in 04-12 F-Series, 05-10 Expedition, 05-12 Lincoln Navigator.
- Ford 6.8L 3V V10 engines used in 05-12 F-Series 250-350-450.
- Note: Tool set covers 1 cylinder head application.



**6683**

#### Ford 1.6L 4V Cam Tool Set

- Works on Ford 1.6L 4V L4 engines used in 11-12 Fiesta.



**6918**

#### Ford Spark Plug Remover Kit, 3V Engine

- Unique design helps prevent breakage by locking the plug porcelain core to the plug hex allowing it to turn as one complete unit.
- Will also pull plug porcelain core if plug hex only is removed.
- Detailed Instructions to maximize success rate.
- Works on:
  - Ford 4.6L 3V V8 engines used in 2005-2008 Mustang, 2006-2008 Explorer.
  - Ford 5.4L 3V V8 engines used in 2004-2008 F-Series, 2005-2008 Expedition, 2005-2008 Lincoln Navigator.
  - Ford 6.8L 3V V10 engines used in 2005-2008 F-Series 250-350-450.

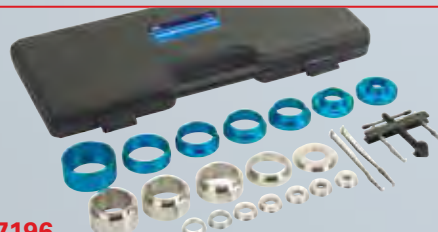

**7196**

#### Crank & Cam Seal Service Kit

- Removes and installs camshaft and crankshaft seals on cars, trucks, vans and SUVs without damage.
- Includes a puller coupled with specialized puller legs that hook the seal for quick and easy removal.
- The interchangeable seal install adapters are designed for use with the cam or crank bolt. Kit services seal sizes of 21.5mm to 64mm.



**7424**

#### Belt Holding Tool

- Keeps belt from falling off of a pulley during belt installation.
- Universal design to fit most pulley styles and sizes.
- Super strong magnet to hold the belt firmly on the pulley.
- Multiple holders can be used for belt applications that fit around many pulleys.
- Durable plastic housing with magnet for steel/iron pulley applications.

### OTC Air Blow Guns



#### OTC PRO Series Lever Air Blow Guns

- Unlike ANY other metal body lever air gun – these incorporate revolutionary Venturi Mechanism that uses side ports to combine free ambient air with costly compressed air – creating a much higher volume of usable output.
- Manufactured from Die Cast Aluminum, the OTC PRO Series Air guns are made to last in the harshest environments.
- Ergonomic design of the body and the large dip coated operating lever reduce fatigue and discomfort – even during extended use.
- Manufactured fully using non corroding materials – threaded 1/4" F at inlet and 1/8" F at outlet.
- Meets OSHA Standards for Safety and Noise.

**2424** – PRO Series Venturi Air Gun (Rubber Tip).  
**2425** – PRO Series Venturi Air Gun (Star Tip).

#### OTC Safety Air Blow Guns

- Impact and Weather resistant Nylon Body
- Safety Venting in all tips
- Corrosion Resistant Stainless Steel Nozzles
- Drop Resistant Construction
- Soft Rubber Grip and ergonomic design for convenience and comfort in extended use.
- Brass threaded air inlet
- Variable speed trigger for control of amount of air dispensed.
- Conforms to OSHA STD 1910-95 (b) for max noise level when used with 90 PSI air pressure
- Conforms to OSHA STD 1-13.1 for safety and are classified as safety Blow Guns.

**2421** – Safety air blow gun, snub nose rubber tip.  
**2422** – Safety air blow gun, 13" stainless steel nozzle.  
**2423** – Safety air blow gun, 4.5" stainless steel bent tip.

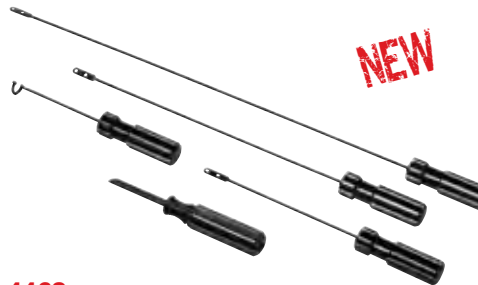

**4462**

#### Wire Loom Threading Kit

The 4462 Wire Loom Threading Kit from OTC is a clever grouping of wire fishing tools for the automotive technician. Whether general wiring R&R - or adding Gauge Packs, Sound Systems, Vehicle Security and Camera Systems, these tools simplify placing the wiring within the protection of existing wiring looms, without cutting tape or zip ties and without damage to other wires.

There are 3 wire pulling tools in 15", 10" and 5.5" lengths for common automotive applications, the grommet insertion tool allows the wire to be captured within the tool to hold once it is placed, placed so you can grab from the opposite side of the firewall - and the pigtail tool assists when building a new harness on the workbench.

### OTC Puller kits

**1060-HYD**

#### OTC 10 Ton Hydraulic Puller Kit

- The OTC 1060-HYD delivers 10 tons of force for industrial bearing service. Engineered for a maximum spread of 17" and maximum reach of 15". OTC Grip-O-Matic® Pullers are designed with adjustable jaw positions in both 2 and 3 jaw configurations. Two pushing adapters are designed to fit the cylinder ram and act as 4.5" and 8.5" forcing screws.
- 10-Ton 2/3 Jaw Grip-O-Matic Puller Chassis.
  - 10-Ton Single Cylinder Hydraulic Ram with 10-Ton Hand Operated Hydraulic Pump.
  - Includes 2 Pushing Adapters (4-1/2" and 8-1/2").
  - Includes 6 Piece Shaft Adapter Set.
  - Ultra Heavy Duty Rolling Storage Case.
  - Comes with a Quick Link Connector for suspending pulling from lifting equipment.



**5 lb. Hammer in Polished Chrome Finish.**



**4579**

#### 9-Way Slide Hammer Puller Set

- Pulls flange-type rear axles and most front-wheel drive hubs.
- Internal and external jaws provide a variety of combinations to pull bearings, gears and seals.
- Two- and three-way cross blocks and cone provide the perfect jaw configuration for most jobs.
- Set also includes a grip wrench adapter and a dent puller attachment for sheet metal or other unique pulling requirements.
- Designed for use with other OTC 5/8"-18 thread slide hammer attachments.
- Packaged in blow-molded case.



**4518**

#### 5-Ton Bar-Type Puller/Bearing Separator Set

- This combination set includes our two most popular bearing "splitters" (2" and 3"), four sets of hex push-puller legs and a bar-type puller head with a 9/16" forcing screw. Separator tools are used with bar puller and legs for a wide variety of pulling jobs.
- The 5" puller cross-bar with a 6-1/4" forcing screw or each of the bearing separators may also be used separately or in combination with other pullers or tools.
- A blow-molded plastic storage case keeps set contents organized and protected from loss.



**4517**

#### 7-Ton Bar-Type Puller/Bearing Separator Set

- Includes a Bearing Splitter with 4" capacity, two sets of hex push puller legs, a 8" bar type puller head mated with a custom thread forcing screw.
- Now service and maintenance professionals have a Puller/Bearing set for tough jobs, up to 7-tons, larger applications, and greater reach 8" to 16".
- As a stand alone puller/bearing splitter set or as a compliment to the 4518 version, the 4517 7-Ton Puller/Bearing Separator Set gives your maintenance/service shop the expanded capability to keep more business in house.

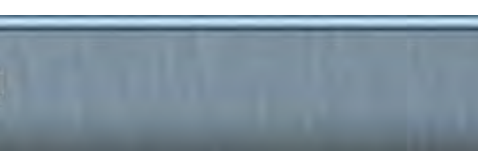

**4534**

#### OTC Multipurpose Bearing and Pulley Puller Set

- For a wide range of pulling jobs, including: bearings, alternators, generators, power steering and crankshaft pulleys, timing gears, and harmonic balancers.
- Set includes drop-forged components, which can be used in a variety of combinations. Contents of Set: 2 – Forcing Screws (Live Center): 3/4"-16 x 6-11/16" and 3/4"-16 x 5" 2 – Cross-bar Yokes: 3 pin-hole @ 3-1/4" to 5-1/2", 2 pin-hole @ 2-3/8" to 3-3/8" 2 – Clamp Bolts 3 – Pairs of Puller Jaws: 1-3/8" Max, 1-5/8" Max, 1-3/4" Max 1 – Pair of Jaw Pins with Ball Spring 3 – Pairs of Capped Bolts
- Spread: 3" to 5", Reach: 1" to 2-1/4"
- Housed in a blow-molded plastic storage case.



**4526**

#### Heavy-Duty Single Pressure Beam Bearing Splitter Set

- Single point of adjustment allows quick attachment of splitter to the application.
- Pressure beam provides the ultimate in secure gripping surface.
- Push Puller is thread matched to the splitter.
- Interchangeable legs shorten or lengthen the range of pull.
- Designed of high quality tool grade materials for a lifetime of use.
- For use on most bushing or bearing jobs up to 4" in diameter.



**4532**

#### 7-Ton Multi Purpose Bearing & Puller set

- Features a classic "H" style puller block accommodating 7-11" application spread.
- Includes 2 sets of forged jaws for a pulling reach range of 5" to 9" – tempered for heavy-duty applications. (Jaws from OTC's 4534 are interchangeable) Two forcing screws are included for short and long pulls.
- Multi applications include heavy-duty pinion bearings, side bearings, alternators, generators, power steering and crankshaft pulleys, timing gears and harmonic balancers.
- Deep set transmission gears and A/C clutches. Roller gears on tracked vehicles, locking collars on pivot shafts.



**4527**

#### 5-Ton Single Pressure Beam Bearing Splitter Set

- Single point of adjustment allows quick attachment of splitter to the application.
- Pressure beam provides the ultimate in secure gripping surface.
- Push Puller is thread matched to the splitter.
- Interchangeable legs shorten or lengthen the range of pull.
- Designed of high quality tool grade materials for a lifetime of use.
- For use on most bushing or bearing jobs up to 3" in diameter.



### SmartTech™ Gloves

#### OTC SmartTech™ Technician Gloves

- Works with touchscreen technology.
- Washable synthetic leather palm with padding ensures comfort and a secure grip.
- Polyester and Lycra material around fingers offer a durable light-weight cover that stretches for a great fit.
- PVC cushions help protect knuckles from injury due to slippage.
- Comfortable polyester back panels include webbing for improved ventilation.



**5801SGLV-M** – Medium.  
**5801SGLV-L** – Large.  
**5801SGLV-XL** – Extra large.

**5931**

#### External Torx® Plus Socket Set (8 piece)

Set includes one each of the following:

No.	Size	Sq. Drive
<b>5931-6</b>	6EP	3/8"
<b>5931-7</b>	7EP	3/8"
<b>5931-8</b>	8EP	3/8"
<b>5931-10</b>	10EP	3/8"
<b>5931-11</b>	11EP	3/8"
<b>5931-12</b>	12EP	3/8"
<b>5931-14</b>	14EP	3/8"
<b>5931-16</b>	16EP	3/8"



**5942**

#### XZN Super Short Socket Bit Set (8 piece)

Set includes one each of the following:

No.	Size	Sq. Drive
<b>5942-4</b>	SP4	1/4"
<b>5942-5</b>	SP5	1/4"
<b>5942-6</b>	SP6	1/4"
<b>5942-8</b>	SP8	1/4"
<b>5942-10</b>	SP10	3/8"
<b>5942-12</b>	SP12	3/8"
<b>5942-14</b>	SP14	3/8"
<b>5942-16</b>	SP16	3/8"



**7175**

#### OTC 3-Piece Indexing Pry Bar Set

- Sizes 10", 12" and 15".
  - Indexable to 180° for better access.
  - 14 locking positions for leverage in multiple applications.
  - Knurled handle assures a sure grip.
  - Meets or exceeds ANSI specifications for pry bars.
- 7172** – 10" Indexing Pry Bar  
**7173** – 12" Indexing Pry Bar  
**7174** – 15" Indexing Pry Bar

### OTC Drain Plug Pro™

**5961HD**

#### OTC Heavy-Duty Drain Plug Pro™

- For Agricultural, Commercial, and Heavy-Duty Vehicle Applications.

**5961**

#### OTC Drain Plug PRO Kit

- Standard drain plug attachment.
- Low profile drain plug attachment.
- 17mm hex attachment for internally driven drain plugs.
- 5/16" bit driver attachment.



### Ford 6.0L Service Tools



**6770**

#### Ford 6.0L Diesel Service Tool Kit

- 8 of our popular 6.0L Diesel Service Tools in one convenient kit.
- Properly test vehicle systems for leaks and blockage.
- Safely remove and re-install harnesses without damage.
- Fuel Filter Cap Wrench, Glow Plug and Injector Harness Release Tools.
- Oil Line Disconnect Tool, EGR Removal Tool.
- IPR Controller, IPR Socket Tool and Fuel Rail Pressure Adapters.

## Oil & Steering Tools

4440

### Heavy Duty 3 Leg Filter Wrench Standard

- Self gripping design for true universal fit from 3" to 4-3/4".
- Heavy duty knurled leg design for extra grip and strength.
- 1/2" square drive with 21mm hex option.



4441

### Heavy Duty 3 Leg Filter Wrench Large

- Self gripping design for true universal fit from 4" to 6 1/2".
- Heavy duty knurled leg design for extra grip and strength.
- 1/2" square drive.



4582



4584

### Jointed Jaw Standard & Large Filter Pliers

- Jointed jaws rotate 180 degrees providing access where standard pliers do not.
- Jaw teeth and cushioned handles provide maximum gripping power for slip free operation.

4582 – Slip joint handle design provides a range from 2-1/4" to 4-3/4".

4584 – Slip joint handle design provides a range from 3-1/8" to 7-1/2".



7484 Standard



7500 Standard

7501 Heavy-Duty

### Inner Tie Rod Wrenches (Standard & HD)

Universal wrench will fit on all styles and allow the technician to un-screw the tie rod link for replacement.

7484 – Unique lever design will turn hex rack ends or hex shafts from 1" to 1-5/8" (25-41mm).

7500 – Unique cam design cover sizes from 1-1/4" to 1-5/8" (33-41mm) hex, 2 flats, round or any style rack ends.

7501 – Unique cam design cover sizes from 1-1/2" to 1-7/8" (38-48mm) hex, 2 flats, round or any style rack ends.

6935

### U-Joint Service Adapter

For use with the 7248 C-Frame to service the u-joints found on Dana 60 4WD front drive axles.



#### Application Examples:

- 1977-1991 Chevrolet and GMC 1 Ton
- 1975-2010 Dodge 3/4" & 1 Ton
- 2000-2002 Ford Excursion
- 1999-2010 F250 and 1985-2010 F350
- 1999-2008 F450 and 1999-2004 F550



6576

6577

6576S includes both 6576 & 6577

6576S

### Dodge Hub Service Set

- Removes stubborn hubs when nothing else will, using 2 methods.
- First, the 6576 Hub Pressing Tool is used to press off the hub with the aid of the power steering. The tool locates spacers between the U-joint yoke and axle housing. Unique design makes this a one person operation to remove the hub with the bearing in tact.
- In the event the Hub Pressing Tool does not budge the hub, the 6577 Hub & Bearing Housing Puller is used. This may separate the bearing, but the unique dual pattern design fits both the wheel hub and bearing housing, capable of applying 20 tons of force.

6576 – Hub Pressing Tool, Fits Dodge 3/4 & 1 Ton 4WD 1994-Present applications.

6577 – Hub & Bearing Housing Puller, Fits Dodge 3/4 & 1 Ton 4WD 1994-Present applications. Also fits GM and Ford 4WD Truck hubs.

## OTC Product Displays



5700-DISPLAY

### 5700-DISPLAY Product Display Rack

- Designed to display various products in the framed rack, complete with removable rear sign holder.
- Sturdy display framed with heavy 5/16" rod with heavy steel base eliminates tipping.
- Contains 2" x 2" = 52 slots, and 2" x 4" = 6 slots.
- Black powder coat finish for a rust free, durable finish.
- Includes 4 side hooks (not pictured).
- Assembled dimensions; W 18.5", D 19", H 44". Weighs approx. 35 lbs.

NEW



Sown with Hammers



Sown with Tire Service Tools

5715

### Tire Spoon Rack

- Designed to hold OTC Tire Spoons by the handle upset.
- Also holds tools with 3/4" or smaller diameter shafts.
- Can be hung on end of tool box or mounted to the wall via holes on 16" center.



## OTC Tire Service

### Tire Service Hammers, Indestructible Handle

- Drop-forged head is induction-hardened for long life, and contains steel locking plates that are specially bonded to ensure the head never becomes loose.
- Use top hook as a wheel tipper; sledge end hook to drag tire into position.
- Bead breaking wedge has grooves and a convex shape to help drive tire lube into the bead.

5789ID-520 – Head Weight 5 lb., Handle Length 20".

5789ID-1032 – Head Weight 10 lb., Handle Length 32".



Handle never needs replacement "Lifetime Warranty".

### Tire Spoons

5735-42

#### 42" Double End Tire Spoon, 3/4" diameter

- Same great design as the original double end mount/demount tire spoon, but in a 42" length for added leverage.

5735-42K

#### 42" Kick Start Double End Tire Spoon, 3/4" diameter

- The -42K includes kick loops to allow the spoon to be forced into tight bead locations with the help of foot pressure.

5713

### Tire Bead Seater

The Tire Bead Seater is used when a tire, new or used, is mounted on a wheel and the tire bead does not touch both sides of the wheel, making inflation possible. The air trigger on this tool expels a tremendous burst of air that inflates the tire to seat it to the wheel rim. This allows the tire to be inflated to the recommended pressure through the tire valve.



5702

### Tire Bead Seater

- The trigger style discharge valve allows for optimum airflow control while allowing both hands to firmly hold the tank/valve assembly, critical for effective and safe use.
- Unique nozzle design significantly reduces "blowback recoil" and contains discharge holes strategically placed for optimum inflation of a wide range of tire sizes and wheel diameters.
- ASME approved 2-gallon tank with inlet valve, pressure gauge, and relief pressure valve for safety.



5776

### Preset Torque Wrench Set;

These color coded click torque wrenches are pre-set to the most common lug nut torque settings, making them perfect for tire shops. Highly durable design can hold up to the toughest tire shop demands.

- No need for adjustments
- Durable satin finish
- 1/2" Drive, 36 tooth
- Quick release ratchet head
- Perfect for Wheel / Tire shop
- Accuracy better than ±3% CW

Sold Individually:

5776-1 – Preset Torque Wrench, 1/2" 65 lb-ft

5776-2 – Preset Torque Wrench, 1/2" 80 lb-ft

5776-3 – Preset Torque Wrench, 1/2" 100 lb-ft

5776-4 – Preset Torque Wrench, 1/2" 120 lb-ft

5776-5 – Preset Torque Wrench, 1/2" 140 lb-ft



6720

### Flare Nut Locking Plier Set (3 pcs.)

- Designed for use on new or damaged flare nuts that have been rounded or rusty.
- Fits Standard or Metric nuts and bolts.
- Angled jaws allow for clearance around frames and bulkheads.

6720-1 – Covers 1/4" to 5/16" (6mm to 8mm)

6720-2 – Covers 3/8" to 7/16" (9mm to 11mm)

6720-3 – Covers 1/2" to 5/8" (12mm to 16mm)



6720-4 – Covers sizes 11/16" to 7/8" (17mm to 22mm). NOT included in 6720 set. Fits nut sizes found on power steering and AC lines.



5047LP

### Lug Nut Cap Remover Locking Pliers

- Designed to remove lug nut caps found on heavy duty truck and trailers quickly and easily without damage. Caps can be easily damaged by prying or using standard cap removers.
- Locking plier design with specially coated jaws apply maximum grip on the lug nut caps without damage.

NEW



5750

### Wheel Tipper

- This ergonomic wheel tipper allows the technician to flip a wheel over during tire service, or just tip up a wheel and tire to move.
- Allows the technician to easily and safely service wheels by eliminating the need to bend over to lift, dramatically reducing the risk of back injury.
- Works on steel or aluminum wheels, inflated or deflated.

NEW

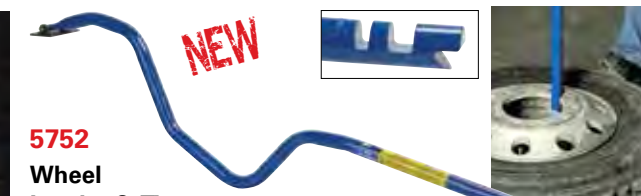

### 5752 Wheel Loader & Tipper

- The new ergonomic wheel loader and tipper integrates two very helpful tools into one.
- The wheel loader feature allows a technician to lift various sizes and types of wheels and tires in and out of a truck bed.
- The wheel tipper feature allows the technician to flip a wheel over during tire service, or just tip up a wheel and tire to move.
- Both of these features allow the technician to easily and safely service and lift wheels by eliminating the need to bend over to lift, dramatically reducing the risk of back injury.
- Works on steel or aluminum wheels, inflated or deflated.



### TCE 4230SFA

#### Swing Arm Tire Changer with Helper Assembly

- Swing arm tire changer designed for servicing standard and occasional high performance tires.
- Services a large variety of tire sizes up to 44" in diameter.
- Includes helper system with 2 points of contact for challenging tire work.
- External clamping capacity up to 26" without the need for adapters.
- Features adjusted jaws with built in inflation.



The pneumatic following arm assists in mounting and demounting low profile tires.



Replaceable plastic inserts protect the rim surface from metal contact to prevent accidental damage.



Telescoping adjustments on the bead breaker shaft increase wheel width and tire diameter capacities.

(P/N 1695101608810 / 5pk)



### WBE 4230 S30

#### Premium Digital Balancer

- Automatic 3D data entry for fast setup.
- Touch-and-Go software eliminates menu steps.
- Fast 6 second cycle time.
- Easy-Fix Auto Locking Weight Positioning Arm.
  - Correct weight placement every time!
- 174 lb. max shaft weight makes it ideal for 1 ton commercial wheels.
- Enhanced, color LCD display for optimal visibility.
- Includes 5 cone set and light truck spacer.



Standard Accessories



### OCL 8850

#### On Car Brake Lathe

#### Bosch Brake Lathes Faster. Better. Stronger

Efficiently corrects lateral runout, DTV (disc thickness variation) and produces a superior finish versus competitive models.

- Standard adapters for 95% vehicle coverage in standard package.
- Delivers the industry's most accurate and precise results for finishing rotors.
- Bidirectional drive unit, eliminating the need to "flip" the lathe.
- Design saves time, eliminates need for full disassembly of brake system.
- Compact design fits in tight wheel wells.
- Mounts to the same machined surface as caliper.



### TCE 4435THP

#### High Performance Tire Changer

- Tabletop system with 24" internal and 22" external clamping.
- Ability to accommodate up to a 43" diameter assembly.
- 25% faster inflation system than benchmarked competition.
- 2 stage variable speed operation for fast operation and quick turnaround.
- Robust 5 1/2" x 5 1/2" automatic tilt tower with pneumatic lock.
- 40% increase in bead breaker power versus the previous model.
- 30% less mount/demount flexion versus benchmarked competitive offerings.
- 3 point helper system automatically maintains proper bead position for effortless orientation.
- Extreme structural rigidity for reduced flexion even for the most difficult UHP or RFT.
- 3 position adjustable bead breaker.
- Equipped with the TCE 320 Assist Assembly and bead breaker board to reduce operator effort on the toughest tire & wheel combinations.



Zeppa Bead Pressing Device (standard)  
(P/N 1695103261810)

## OTC Equipment



5300

#### OTC Stinger 3-Ton Jack Pack

- This jack pack includes a 3-ton service jack (5303) with lifting range of 5-3/4" to 18-1/2" and a pair of 3-ton jack stands (5372) with a base of 8-1/4" x 7-1/2" and height range of 12" to 17-11/16".

#### 2-1/4 - / 3-Ton Hydraulic Service Jacks

- Flanged upper body edge increases strength to resist twisting.
- Built-in safety overload system/ prevents use beyond their rated capacity.
- Rear swivel casters, for easy maneuvering and positioning.
- These jacks have 4" saddle dia., 21" overall reach, 6-1/2" frame height, 39-1/2" handle length, and a floor space of 13-1/2" x 24-1/2".

5302 – 2-1/4-ton capacity with a lifting range of 5" to 18".

5303 – 3-ton capacity with a lifting range of 5-3/4" to 18-1/2".



5302

1780

#### OTC Stinger 22-Ton Capacity Jack Stands

- Height range is 13-7/8" to 19-7/8".
- Saddle size 3" x 3-3/4".
- Pin-style (non-ratchet) three positions, 3" intervals.
- Reinforced collar to meet newest ANSI PALD test standards.
- 11" flat base prevents sinking into the surface.



5372

#### OTC Stinger 3-Ton, 6-Ton and 12-Ton Jack Stands

- Formed and welded steel base for strength; self-locking ratchet handle cannot be released under load. Durable baked enamel finish resists corrosion.
- Stands conform to ANSI PALD load rating standard; factory tested before shipment.

5372

- Pair of 3-ton jack stands.
- Base: 8-1/4" x 7-1/2".
- Height range: 12" to 17-11/16".

5373

- Pair of 6-ton jack stands.
- Base: 11-9/16" x 10-3/8".
- Height range: 15-5/8" to 23-11/16".

1784D

- Pair of 12-ton jack stands.
- Base: 12-1/8" x 10-7/8".
- Height range: 17-1/2" to 27-1/2".



4012

#### Two-Speed Hand Pump

This two-speed pump is ideal for use with single-acting rams or combinations where 45 cu. in. of usable oil capacity will do the job. Has 2-way valve; welded steel carrying handle; automatic switching from low to high pressure mode; handle effort under 140 lbs. at 10,000 PSI; unique fill cap to prevent over-filling and over-pressurization; non-vented reservoir; fingertip control valve with 180° throw for on/off control.

### 5286

#### OTC Portable Diesel Particulate Filter Cleaner

- The advent of the 2010 Tier 4 cleaning requirements created the need for a lighter, more portable cleaning system which can be taken into the field to clean filters at the point of service.
- Lightweight and Highly Portable - ideal cleaning system for use in the shop or on a service truck.
- Flexibility - clean DPF's from 6" to 15.5" in diameter using shop or compressed air of at least 100 PSI.
- Fully Automated Operation - once started, the cleaning process can be completed unmonitored, freeing up technician to simultaneously do other work in the shop.
- Focused Air Jet Technology™ - concentrates a precise high pressure stream of air directly into every cell.
- Maximum Efficiency - OTC's unique floating puck prevents "splash back," which maximizes the volume of air entering each cell.
- Easy Maintenance - contains no internal filters that require user maintenance and its rugged design provides maximum durability.



### 5025

#### Diesel Exhaust Fluid (DEF) Refractometer

- SCR & EPA 2010
- EPA regulations require all diesel engines manufactured on or after January 1, 2010 to meet lowered NOx emissions standards.
- Scale: 0.5% line graduations 32.5% Indicated Scale 15-40% Waterline & 20 Deg C
- Application: The refractometer is a portable, precision, optical instrument used for measuring the Diesel Exhaust Fluid (DEF) concentration. When a liquid sample is placed on the prism, the light passing through it is bent and shows on the scale to indicate the DEF condition.

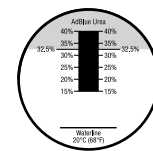

### 3095

#### Heavy-Duty Digital DEF Tester

Ensure the proper operation of Class 7-8 trucks utilizing the SCR system with accurate Diesel Exhaust Fluid solution displayed on screen.

- Digital Display
- Displays % UREA
- Displays washer fluid freeze point

The OTC 3095 makes testing a simple and quick process for an operator or technician.



### 5281

#### OTC DPF Thermal Processing Unit

- Designed to facilitate the cleaning of filters – with high amounts of wet soot, and unburned hydrocarbons.
- Pre-programmed thermal profile controls temperature 'ramp up' and 'cool down' to reduce the risk of cracking the DPF.
- Includes "pre-treat" cycle for oil-soaked filters.
- Holds temperature constant for two hours to ensure complete regeneration of filter.
- Built-in electronic safety lock prevents unauthorized opening of the door when temperatures exceed 200 degrees F.
- Large chamber accommodates various DPF sizes and shapes. Front access door allows for easy access to the thermal chamber.



### 4026

#### Air/Hydraulic Power Unit

- Heavy-duty aluminum body for durability and light weight.
- 10,000 PSI air/hydraulic pump.
- A perfect replacement pump for body and frame straightening equipment.
- Performs in either vertical or horizontal positions.
- Rotary-style pressure release provides superior operator control.



#### OTC 9300 Stinger Series Bottle Jacks give you lifting range from 2 to 50 tons.

With a forged base and cylinder to ensure strength and eliminate leaks, you can lift it all. Featuring a chrome piston pump and ram for additional rust resistance.

- 9302 – 2-Ton
- 9303 – 3-Ton
- 9305 – 5-Ton
- 9308 – 8-Ton
- 9312 – 12-Ton
- 9314 – 8-Ton Shorty
- 9320 – 20-Ton
- 9322 – 20-Ton Shorty
- 9330 – 30-Ton
- 9350 – 50-Ton



## OTC Heavy Duty

**5105B**

### 1,100 lb. Capacity High-Lift Dual Wheel Dolly

- Effortless air-powered hydraulic lift system for a variety of applications.
- 0 to 42" lifting range.
- Six-inch lateral adjustment.
- Tilt adjustment of +15° to -8° ensures easy alignment.
- Features four swivel casters, two locking, for enhanced mobility.



**5292**

### 27.5-Ton Capacity Under-Axle Jack

- Features class-leading 27.5 ton capacity.
- Robust design with completely sealed piston.
- New lever design and pneumatic release valve for more precise release control.
- Power return allows lowering with no load.
- Includes two height adapters for flexibility.
- PALD compliant.
- Minimum retracted height (with saddle only): 8-1/4".
- Maximum extended height (with screw extended and large adapter): 21-3/8".
- Stroke: 4.9375".
- PSI range: 90 to 175.



**5015A**

### Truck Clutch & Flywheel Handler

- Handles 14" and 15-1/2" clutch assemblies weighing up to 150 lbs.
- Lifting range of 9" to 37". Swivel casters provide easy maneuverability.
- Includes a 2" spline shaft with a 1-1/4" pilot to aid in alignment.



**1520**

### Mobile Vehicle Lift System (Includes two lifts)

- Mobile, tandem system is air-operated to handle your class 7 and 8 tractor lifting needs. No need to waste time re-blocking and making additional lifts for the clearance you need for under-vehicle service. Roll the system to the vehicle anywhere in the shop or outside on a level surface.
- Unique design provides lift from the tires, not the frame or axle members. Ideal for situations where limited ground clearance or a lack of clear access complicates lifting.
- Single controller operates both sides of the system for a smooth, level lift up to two full feet from the bottom of the tires to the ground. Units can double as support stands when retention pin is inserted.
- Covered by OTC Lifetime Marathon Warranty®.



## OTC Series

### 4- and 10-Ton Collision Repair Sets

- Components snap together, permitting you to apply pushing, spreading.
- Components include: hydraulic pump, hose, and ram; ram flat base; 1/2-ton hydraulic spreader; extension tubes (4); tube coupling; ram toe; wedge head; serrated saddle; flex head; plunger toe; 90° wedge head; storage case. The case for the 10-ton set has wheels for mobility.

**1517A** – 4-ton collision repair set. Has single speed hydraulic hand pump and ram with 5" stroke.

**1519A** – 10-ton collision repair set. Has two-speed hydraulic hand pump and ram with 6-1/8" stroke.



### OTC Transfer Tanker

- Draining oil from a large displacement engine and getting it to your bulk storage container is a snap.
- Used oil is collected in the 15-gallon reservoir, and then rolls smoothly on 4" free-wheeling casters to your storage location.
- Pump moves five gallons a minute through the 8-foot transfer hose.
- Low profile, measures 7-1/2" from floor to top of reservoir.
- Can also be used for transferring antifreeze.

**5097** – Transfer Tanker equipped with a pneumatic pump (No. 529966).

## OTC Service Jacks

### 5-Ton and 10-Ton Service Jacks

- A built-in safety overload prevents using the jack beyond its rated capacity.
- Convenient foot pedal speeds the lifting operation. Handle lock and release control are located on top of the handle. Handle can be locked into any position from vertical to horizontal.
- Spring-loaded 40" handle.

**1505B** – 5-ton service jack. Lifting range 6" to 22".

**1510B** – 10-ton service jack. Lifting range 6-1/4" to 22".

### 20-Ton Capacity Service Jack

- Low-profile stance and extended height add to versatility.
- Wheels and swivel casters feature internal bearings.
- Either the foot pedal or jack handle may be used for pumping action. Counter-balanced, spring-assisted handle has a three-position lock.

**1512** – 20-ton service jack. Lifting range 7-1/2" to 24".



### 2- & 3-Ton Service Jack

- Ergonomic handle for user comfort & easy mobility.
- Foot pedal for quick approach of the lifting saddle to load. Built-in tray for fasteners and tools.
- CE certified, PALD compliant.
- Covered by OTC Lifetime Marathon Warranty®.

**5202** – 2-ton service jack. Min. height 3"; Max. height 18-1/4".

**5203** – 3-ton service jack. Min. height 5-1/2"; Max. height 20-1/2".



### 6- & 10-Ton Heavy-Duty Service Jack

- Ergonomic handle for user comfort & easy mobility.
- Foot pedal for quick approach of the lifting saddle to load. Built-in tray for fasteners and tools.
- CE certified, PALD compliant.
- Covered by OTC Lifetime Marathon Warranty®.

**5206** – 6-ton HD service jack. Min. height 6-11/16"; Max. height 22-13/16".

**5210** – 10-ton HD service jack. Min. height 6-11/16"; Max. height 23-13/16".



**1533**

### OTC Aluminum Racing Jack Pack

- Jack lifts two tons and weighs only 43 lbs.
- Five pumps to max. height – 18".
- Low profile 3-1/2" makes it perfect for ground hugging, high performance cars.

**1582** – 2-ton aluminum jack stands. 10-1/4" min. height, 15-1/4" max. height. Made from aircraft-grade aluminum.

### 2,000 and 4,000 lb. Capacity Folding Floor Cranes

- Both cranes fold up for compact storage
- Front wheels are 3-1/2" in diameter
- Rear casters are 5-7/8" in diameter

**2002** – 2,000 lb. capacity with a reach of 24" to 36"

**2004** – 4,000 lb. capacity with a reach of 25" to 46"

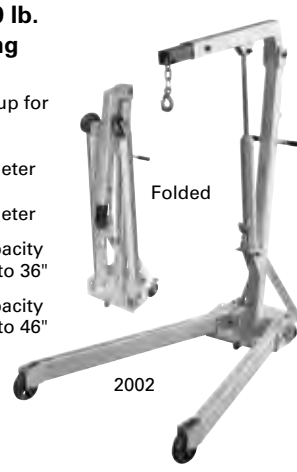

### 6,000 lb. Capacity Heavy-Duty Mobile Floor Cranes

- Three boom positions for capacities of 4,000, 5,000, and 6,000 lbs for large engines and engines/transmissions combined.
- Usable reach of nearly 92".
- Boom swivels for vertical and lateral positioning.
- Legs extend to straddle extremely large tires.

- 1814** – 6,000 lb capacity crane with electric/hydraulic pump and remote control.
- 1813** – 6,000 lb capacity crane with two-speed hydraulic hand pump.



### OTC Rear Suspension Bushing Tool

- Removes FAS II Airliner Freightliner Rear Suspension bushings in a fraction of the time of traditional methods.
- Saves on average 45 minutes per bushing (4 per vehicle) on flat rate of 1.5 hours per bushing.

**4244** – Freightliner Rear Suspension Tool.

**4245** – Freightliner Rear Suspension Tool – Master Kit includes 2510A Air/Hydraulic Pump.



**4295**

### Wheel Stud Service Kit

- Installation done by pushing on the head, eliminating the need for threaded adapters.
  - Reduces number of adapters required
  - Reduces damage to studs, hubs and bearings
  - Increases ease of use
- Remove and install 10 studs in only 10-15 minutes
- Can be powered with an impact wrench, no hydraulic power source required.
- No need to remove hub from vehicle.

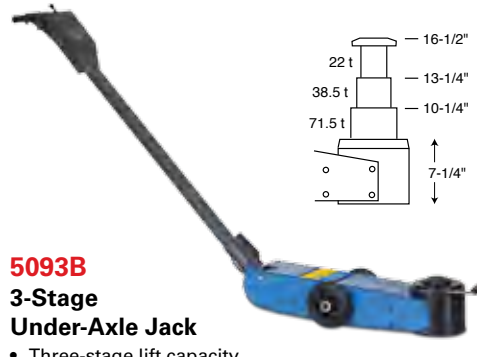

**5093B**

### 3-Stage Under-Axle Jack

- Three-stage lift capacity 20T, 35T, and 65-tons. Ideal for lifting loaded trailers, buses, and other Class 7 & 8 vehicles.
- Features a high load-approach speed.
- Air-driven cylinder with pressure control knob for maximum user safety.
- 4-position handle: horizontal, 45 degrees, vertical, or collapsed.
- 7-inch minimum height for low clearance vehicles.
- Comes with a 3-15/16 in. (100 mm) lifting extension.
- Complies with ASME / PALD test requirements.



**5130**

### OTC 1,000 lb. Capacity DriveMaster™ Driveline Lift

- Low profile of 7".
- Lift range: 23" to 30".
- Pivoting pump handle +/- 15° tilt in each direction.
- Includes 553516 differential mounting adapter. Mounts easily using existing bolt patterns. Fits the most common differentials currently in use on Category 7 and 8 Heavy Duty Trucks. Including: Eaton, Fuller, Rockwell, Meritor, Spicer, International, and Mack.
- CE certified, PALD compliant.

### Optional adapter kits

- 558382** – Auxiliary box adapter.
- 561949** – Light duty transmission adapter.

### OTC Power Train Lift

- These lifts will handle engine and transmission assemblies, gas tanks, drive axle assemblies, engine/transaxle assemblies, electric bus batteries, and more.
- Scissors-type design allows access to all four sides of a component.
- Lifting and lowering motion controlled by hand-held remote.
- Table tilts ±15° side-to-side, or fore and aft.
- 20" x 32" tilt table.
- Larger casters accommodate heavy loads.

**5285** – 1,650 lb. Capacity Lift. Air / hydraulic operation – Foot control pump (2510A) with hose allows movement around lift. Minimum height is 29" with an 72" maximum height.



Covered by OTC Lifetime Marathon Warranty®.



**1585A**

### Power Train Lift 1,250 lb. Capacity

- For easy removal and installation of engine/transaxle assemblies on FWD vehicles. Also handy for pulling rear ends, leaf springs, and more.
- Includes 4020 air/hydraulic pump.
- Your shop air supply is the only thing you need to get the precise control offered by this OTC power train lift.
- Width between wooden support blocks is adjustable from 0–29". Load is secured with a tough nylon strap.

**5078**

### Air-Assisted 2,000 lb. Capacity High-Lift Transmission Jack...for Trucks & Buses

- Low height of 41-1/2" allows transmission to be rolled out from under vehicle's frame.
  - Foot-operated air pump enables the operator to effortlessly raise the transmission into place.
  - Rugged, heavy wall tubing and oversized base for stability.
  - A dedicated adapter for Allison 500- and 600-series automatic transmissions is included.
  - Covered by OTC Lifetime Marathon Warranty®.
- Specifications:**  
 Min. height is 41-1/2" Max. height is 65"  
 Max. forward Tilt – 50° Max. backward tilt – 38°  
 Max. side tilt (either side) – 14°  
 Leg width – 46"



**1770A**

### 1,500 lb. Dual Wheel Dolly

- Hydraulic jack provides almost 5" of lift and tilts wheel assembly 4° to prevent damage to wheel seal.
- Independent lifting rack provides maximum stability; rollers won't catch on load.
- Swivel casters for easy maneuverability.
- Floor space is 45" by 41".
- 6' chain holds load in place.
- Covered by OTC Lifetime Marathon Warranty®.



# MUSCLETOOLS

## Robinair A/C Diagnostics



34288



34788



34788-H



34988

Features:	34288	34788	34788-H	34988
Fully-Automatic Function: Program to recover, vacuum, leak test and charge without operating panel valves.		X	X	X
Automatic Dye Inject: Gives the user the ability to use the machine to inject UV dye into a vehicle's A/C system.				X
Automatic Oil measure & Inject: The machine will automatically determine how much lubrication oil needs to be injected back into the A/C system based on how much oil was taken out during recovery.				X
Automatic Oil Drain: A display reminds you to empty the graduated container to show the amount of oil to replace.		X	X	
Oil Inject: Automatically inject oil back into the vehicle A/C systems.		X	X	
Refrigerant & Oil Database: A/C system capacities for North American market vehicles.		X	X	X
A/C system flush: Flushes a vehicle's A/C system with refrigerant eliminating any residual oil or other liquid. (Flushing adapters - not included)				X
Save & Print before and after service data: Allows the user to store before and after service information by vehicle and print this information to provide to a customer.				X
Indicator light and notification alarm: Notifies the user when service is complete, or if a problem has occurred.		X	X	X
Vacuum Leak Test: Monitors level after evacuation, informs of possible leak.	X	X	X	X
Automatic Air Purge: Eliminates damaging air without monitoring gauges or opening valves.	X	X	X	X
Automatic Refrigerant Refill: Maintains a user-selectable amount of refrigerant in an internal vessel and signals with it's time to change supply tank, no monitoring required.		X	X	X
Vacuum Feature: Defaults to 15 mins, programmable up to 99 mins. "Remaining time" is displayed.	X	X	X	X
Display: Multilingual	X	X	X	X
Refrigerant Charging: Select a charge mode from high or low side.		X	X	X
Refrigerant Management System: Displays refrigerant use and monitors remaining filter life. Prompts appear when 1/3 of filter life remains.	X	X	X	X
Capable of servicing high voltage electric compressor A/C systems			X	

### Multi-Purpose and Coolant Fluorescent Dye

**MULTI-PURPOSE** (engine oil, transmission) 16244, 16245  
**COOLANT** 16885, 16890



**16244** 6 applications  
**16885** 6 applications  
**16890** 32 applications  
**16245** 32 applications

### 16009 DiscovR Refrigerant Identifier

• Fast and Accurate. "Pass" and "Fail" lights clearly show if refrigerant is pure enough to be recovered.

#### Product Specifications:

Refrigerant: R134a  
 Input Power: 12 VDC  
 Accuracy: Pass/Fail - 95% pure R134a  
 Air Detection: Yes  
 Approvals: SAE J1771, UL/C



### TIFZX Heated Pentode® Refrigerant Detector

• Heated Pentode® sensor technology  
 • Tri-color visual leak size indicator  
 • Detects all CFC, HFC, HCFC's including R-12, R-22, R-123, R-134a, R-404a, R-407a, R-408a, and R-410a.



### 22791 InfraRed Refrigerant Leak Detector

• Advanced infrared sensor designed to last a minimum of 10 years.  
 • Three sensitivity levels down to 0.15 oz./year.  
 • Automatically recalibrates in highly contaminated areas to help pinpoint the exact location of the leak  
 • Won't trigger on oil or moisture.



## Robinair Manifolds

### 2-Way Brass Manifold



**44150** Dual R12/134a Kit

**45111** R134a Manifold Hose Kit

### 2-Way Aluminum Manifold



**48510** R134A  
 • 90° Manual couplers  
 • 72" R134a Hose Set (1/2" ACME x 14mm)

**47150** Dual R12/134A  
 • 90° Manual couplers  
 • 72" R134a Hosea Set (1/2" ACME x 14mm)  
 • 72" R12 Hose Set (1/2" ACME x 1/4" MFL)

### Economy Manifolds



**48134A**  
 R134 brass manifold, hose set and service couplers

**49134A**  
 R134 aluminum manifold, hose set and service couplers

### 75700 Coolant Exchanger

• Our 10 minute exchange process means no more waiting for the engine to warm up!  
 • Our "Engine Off" feature removes pulleys, belts, and fan blades from the safety equation.



### 75240 Coolant and Battery Refractometer

Coolant scale range: 32° F/0° C to -60° F/-51° C.



### Econo-Clean Coolant Service Accessories

**75134** – Coolant test strips.  
**75234** – 3-way heavy-duty truck coolant test strips.



### 92500 Transmission Fluid Exchanger

You can have the vehicle in and out of the service bay in less than 20 minutes!

Operate through dipstick only, cooler line or a combination of the two!

• Exchange accuracy approx. +/- 1/4 qt.  
 • 32-qt. supply tank; 34-qt. waste tank.



### UV Leak Detection Kits

• The easiest and most accurate gun available today.  
 • No guesswork – a pre-measured application every time.  
 • One squeeze injects a pre-measure amount (1/8 oz.) of dye. No more adding too much dye.



16234

16235

### A/C Fluorescent Dye

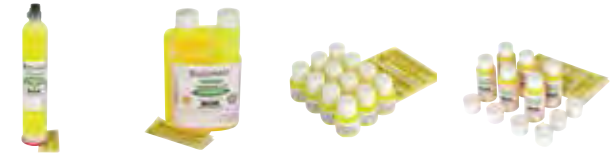

**16240**  
 64 applications  
 One 8 oz. bottle

**16241**  
 64 applications  
 One 8 oz. bottle

**16242**  
 12 applications  
 Twelve 1/4 oz. bottles

**16243**  
 24 applications  
 Six 1 oz. bottles

### TIF9010A

#### Slimline Programmable Scale

• Completely portable refrigerant scale, battery powered, can be used with all refrigerants.  
 • Extreme accuracy.  
 • 110 lb./50 kg capacity.



## Robinair Vacuum Pumps

### VacuMaster® Single Stage Vacuum Pumps

**15115** – 1.5 CFM Vacuum Pump.  
**15310** – 3 CFM Vacuum Pump.  
**15510** – 5 CFM Vacuum Pump.



### VacuMaster® 2-Stage Vacuum Pumps

**15150** – 1.5 CFM Vacuum Pump.  
**15300** – 3 CFM Vacuum Pump.  
**15500** – 5 CFM Vacuum Pump.



### CoolTech® Vacuum Pumps

**15434** – 4 CFM Vacuum Pump.  
**15600** – 6 CFM Vacuum Pump.

