

Belt Tension Gauge

Operating Instructions

1. Fully depress the ball so the hook engages the belt. See Figure 1.
2. Hold the gauge square to the edge of the belt, and release the ball using a quick, snapping motion. See Figure 2.
3. Read tension units (pounds, newtons, etc.) on the dial face, across from the indicator on the gauge body.
4. Set belt tension to manufacturer's specifications.
5. Remove gauge from belt before starting the engine.

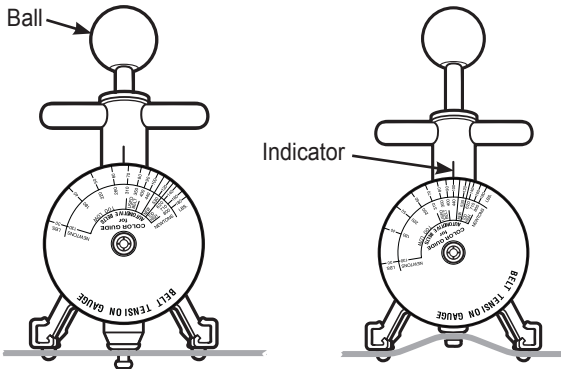

Figure 1

Figure 2

Usage Tips

- Readings will vary slightly in different locations on the same belt due to irregularities in belt composition.
- Avoid testing on a spliced area of the belt.
- The gauge is accurate only on the type of belt for which it is designed. Use a gauge designed to cover the full belt width; a gauge that picks up only one edge of a wide belt will not supply an accurate reading.

⚠ Caution: To prevent personal injury or damage to the gauge,



- Wear eye protection that meets ANSI Z87.1 and OSHA standards.

- Do not drop the gauge.

- Do not use a snapping motion to release the ball unless the gauge is mounted on a belt.
- Keep the gauge clean to prevent foreign matter from entering the housing and causing internal damage to the gauge.

OTC

Belt Tension Gauge

Operating Instructions

1. Fully depress the ball so the hook engages the belt. See Figure 1.
2. Hold the gauge square to the edge of the belt, and release the ball using a quick, snapping motion. See Figure 2.
3. Read tension units (pounds, newtons, etc.) on the dial face, across from the indicator on the gauge body.
4. Set belt tension to manufacturer's specifications.
5. Remove gauge from belt before starting the engine.

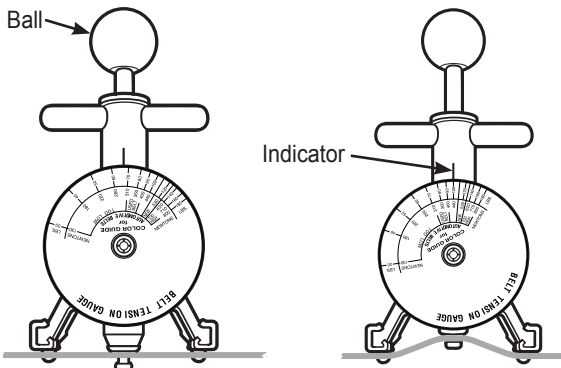

Figure 1

Figure 2

Usage Tips

- Readings will vary slightly in different locations on the same belt due to irregularities in belt composition.
- Avoid testing on a spliced area of the belt.
- The gauge is accurate only on the type of belt for which it is designed. Use a gauge designed to cover the full belt width; a gauge that picks up only one edge of a wide belt will not supply an accurate reading.

⚠ Caution: To prevent personal injury or damage to the gauge,



- Wear eye protection that meets ANSI Z87.1 and OSHA standards.

- Do not drop the gauge.

- Do not use a snapping motion to release the ball unless the gauge is mounted on a belt.
- Keep the gauge clean to prevent foreign matter from entering the housing and causing internal damage to the gauge.

OTC

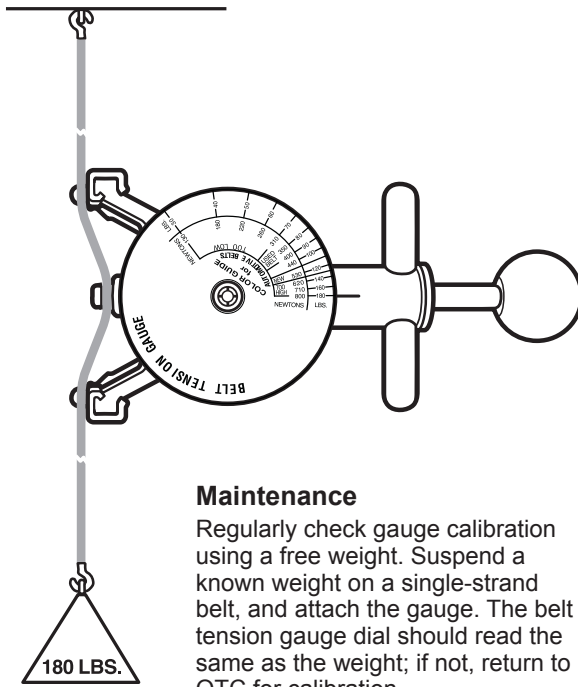

Maintenance

Regularly check gauge calibration using a free weight. Suspend a known weight on a single-strand belt, and attach the gauge. The belt tension gauge dial should read the same as the weight; if not, return to OTC for calibration.



655 Eisenhower Drive
 Owatonna MN 55060
 Customer Serv.: 800-533-6127
 Fax : 800-283-8665
 Technical Serv. : 800-533-6127
 Fax : 800-955-8329

© Bosch Automotive Service Solutions Inc.

Form No. 517913
 Rev. C, March 6, 2015

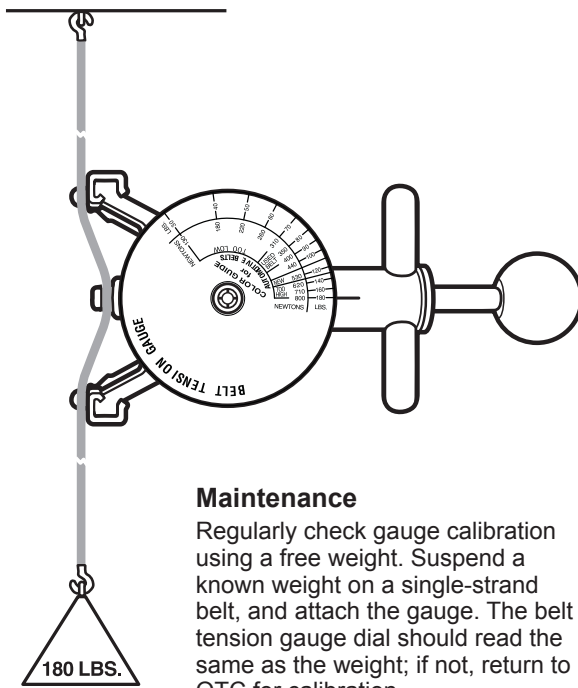

Maintenance

Regularly check gauge calibration using a free weight. Suspend a known weight on a single-strand belt, and attach the gauge. The belt tension gauge dial should read the same as the weight; if not, return to OTC for calibration.



655 Eisenhower Drive
 Owatonna MN 55060
 Customer Serv.: 800-533-6127
 Fax : 800-283-8665
 Technical Serv. : 800-533-6127
 Fax : 800-955-8329

© Bosch Automotive Service Solutions Inc.

Form No. 517913
 Rev. C, March 6, 2015