

Rear Seal Repair Kit

Application : 7.3L Diesel Engines

Parts List &
Operating Instructions for:

7835

Parts List

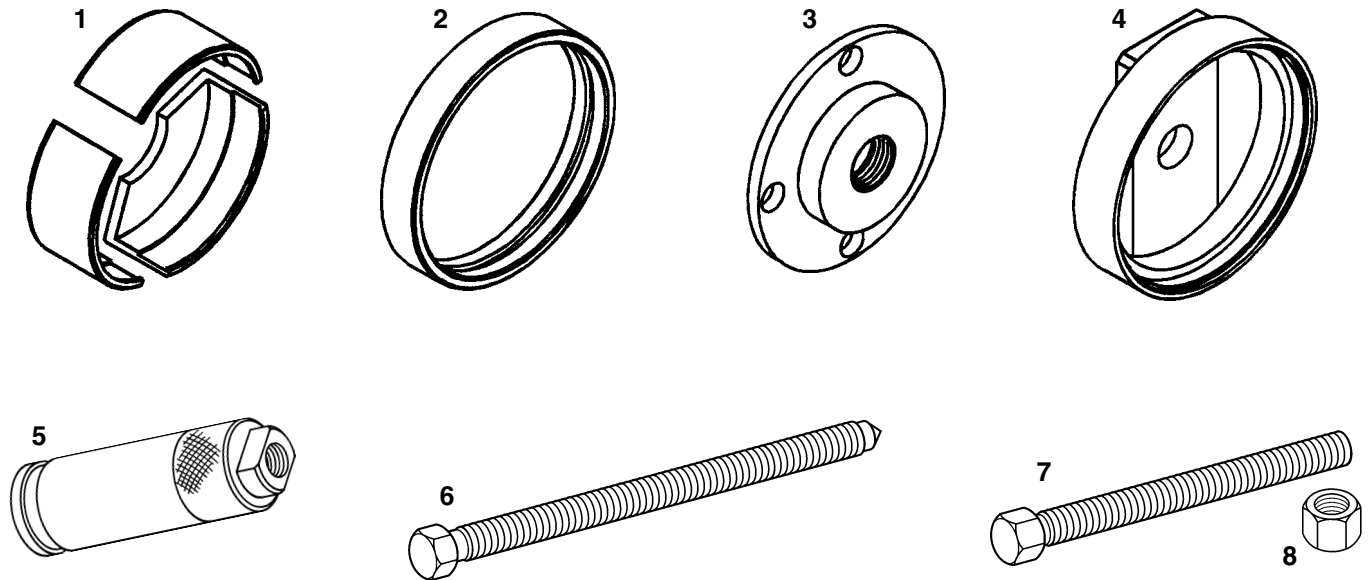

Item	Part No.	Qty.	Description
1	523614	3	Crankshaft Rear Wear Ring Remover Jaws
2	523615	1	Crankshaft Rear Wear Ring Sleeve Remover / Installer
3	523616	1	Centering Tool
4	523617	1	Crankshaft Seal Installer
5	523618	1	Receiver Tube
6	523619	1	Forcing Screw
7	523620	1	Forcing Screw
8	19528	1	Hex Nut

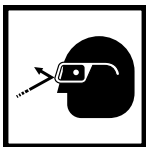

WARNING : To prevent personal injury when using these tools, wear eye protection that meets ANSI Z87.1 and OSHA standards.

Sheet No. 1 of 2

Issue Date: Rev. B, 6-17-04

Removal

1. Remove the five crankshaft rear oil seal retaining bolts and the crankshaft rear oil seal. See Figure 1.
2. Clean the crankshaft rear oil seal sealing surfaces.

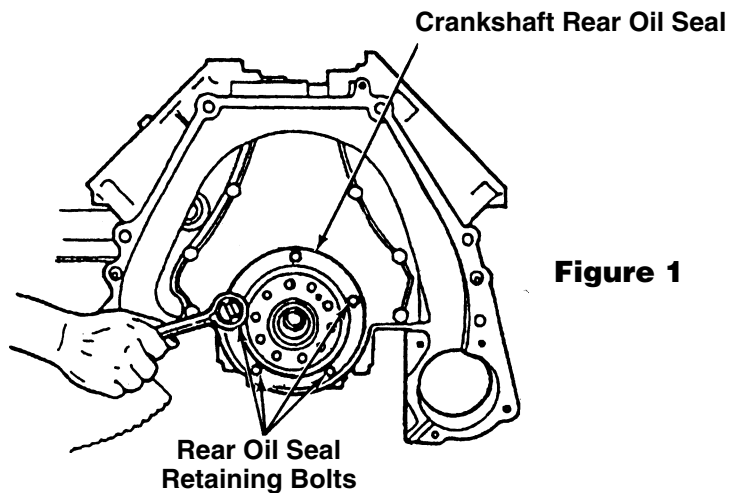

Figure 1

If the Engine is Equipped with a Crankshaft Wear Sleeve :

1. Thread No. 523619 forcing screw into the No. 523618 receiver tube. See Figure 2.
2. Position No. 523614 wear ring remover jaws on the receiver tube.
3. Place the remover jaws over the wear ring on the crankshaft.
4. Place No. 523615 wear ring remover sleeve over the remover jaws.
5. Tighten the forcing screw to remove the crankshaft wear ring.

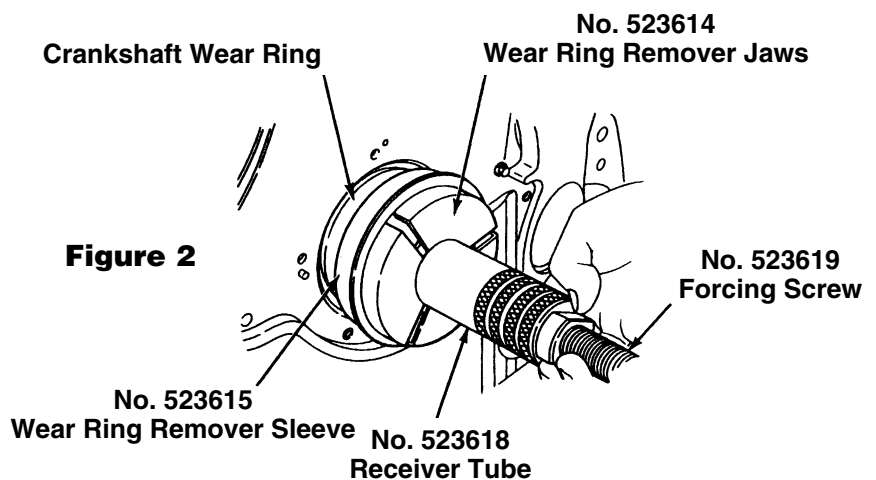

Figure 2

Installation

1. Fasten No. 523616 centering tool to the crankshaft flange using two cap screws provided. See Fig. 3.

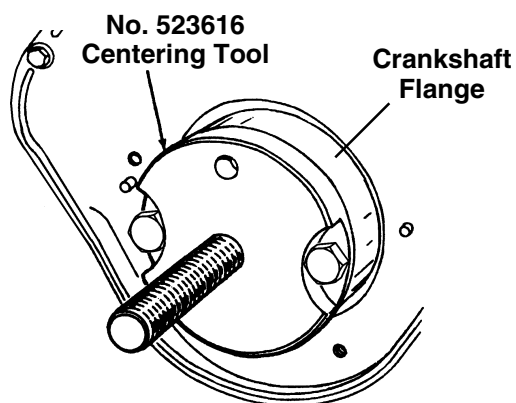

Figure 3

2. Apply a bead of silicone rubber (RTV) sealer around each bolt hole and the inside diameter of the bolt hole pattern to the seal. See Figure 4.

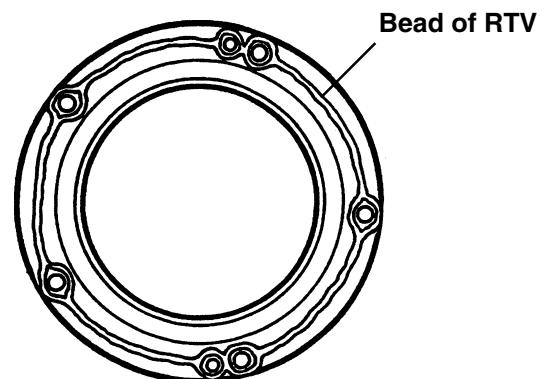

Figure 4

Installation contd.

- Place the seal and wear sleeve assembly over the centering tool. See Figure 5.

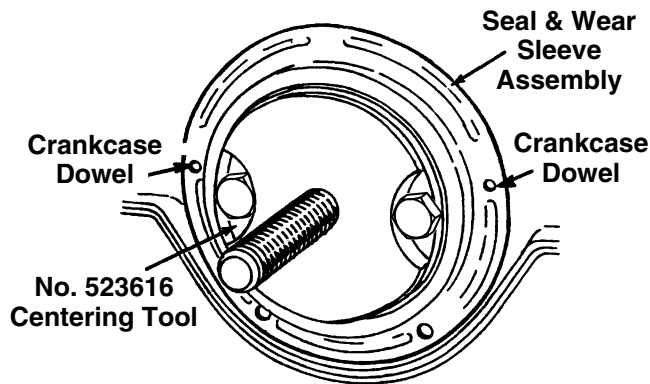

Figure 5

- Install the No. 523617 seal installer inside the wear sleeve installer. See Figure 6.

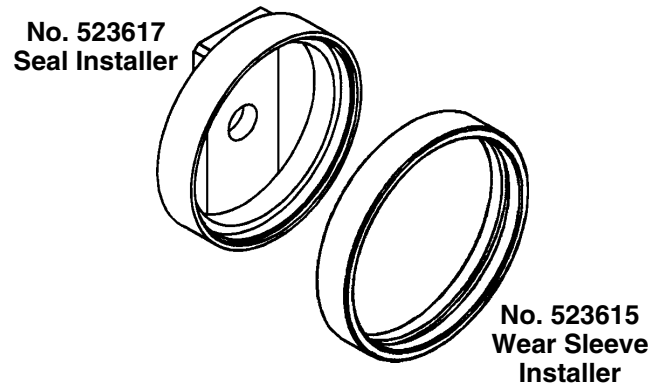

Figure 6

- Install the seal installer and No. 523615 wear sleeve installer over the centering tool. Thread No. 19528 hex nut onto No. 523620 forcing screw. Install forcing screw assembly through the seal and wear ring installer into the centering tool. Tighten the nut on the forcing screw to press the seal and wear ring into place. See Figure 7.

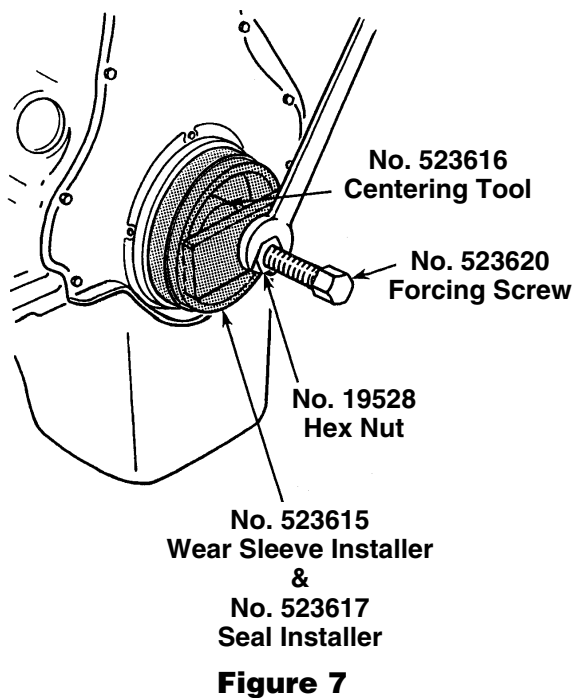

Figure 7

- Align the bolt holes in the seal with the bolt holes in the engine block. Install and torque the five bolts according to OE specifications. See Fig. 8.

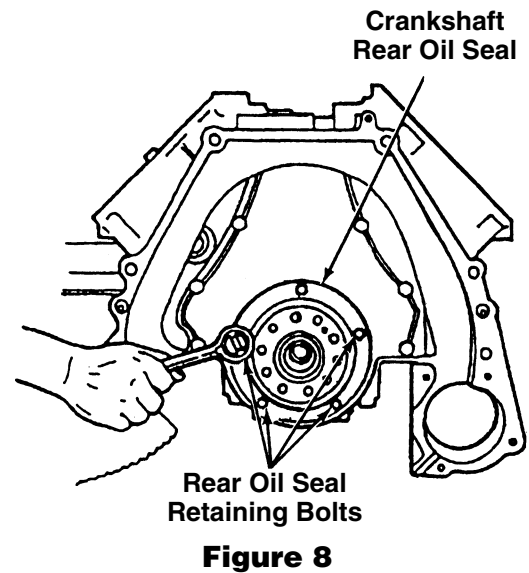

Figure 8