



655 Eisenhower Drive  
Owatonna, MN 55060 USA  
Phone: (507) 455-7000  
Tech. Serv.: (800) 533-6127  
Fax: (800) 955-8329  
Order Entry: (800) 533-6127  
Fax: (800) 283-8665  
International Sales: (507) 455-7223  
Fax: (507) 455-7063

Form No. 580824

Parts List and  
Assembly Instructions for: 1630

## Two-Drawer Service Cart

Capacity: 500 lbs. (226.8 kg) Total Weight Load  
Locking Top



### Safety Precautions



**WARNING:** To prevent personal injury and/or equipment damage,



- Read, understand, and follow all safety precautions and operating instructions included with this service cart. If the operator cannot read these instructions, operating instructions and safety precautions must be read and discussed in the operator's native language. Only qualified operators should install, operate, adjust, maintain, clean, repair, or transport this equipment.



- Wear eye protection that meets ANSI Z87.1 and OSHA standards.
- Do not exceed the rated capacity of the cart.
  - Total Net Load: 500 lbs. (226.8 kg)
  - Top and Bottom Shelf: 150 lbs. (68 kg) each
  - Center and Bottom Drawers: 70 lbs. (31.75 kg) each

Sheet No. 1 of 2

Issue Date: Rev A, May 2, 2017

## Assembly Instructions

### Tools Needed

1. Tabletop or workbench (must support 150 lbs. [68 kg]; cover to prevent damage to surface)
2. Two people
3. 13 mm wrench
4. Ratchet with 13 mm socket
5. Adjustable wrench

### Assembly

#### Step 1 - Attach Casters

1. Turn bottom tray upside down.
2. Align holes in locking and non-locking casters with matching holes in the bottom tray. See Figure 1.
3. Attach washers and nuts from caster bolt kit and hand tighten.

#### Step 2 - Align the Legs

1. With the drawer assembly lid open, place two of the four legs face up on the table. See Figure 2
2. Place the drawer assembly and bottom tray on supports and align with matching holes in legs.

#### Step 3 - Attach the Handles

1. Align the other legs with the front corners of the bottom tray and drawer assembly and let them rest on top. See Figure 3.
2. Align the hole on the handle with the second hole down on the drawer assembly and (unattached) leg.
3. Insert handle bolts through handle, through the leg, and into the drawer assembly.
4. Secure with washer and nut from handle bolt kit and hand tighten.

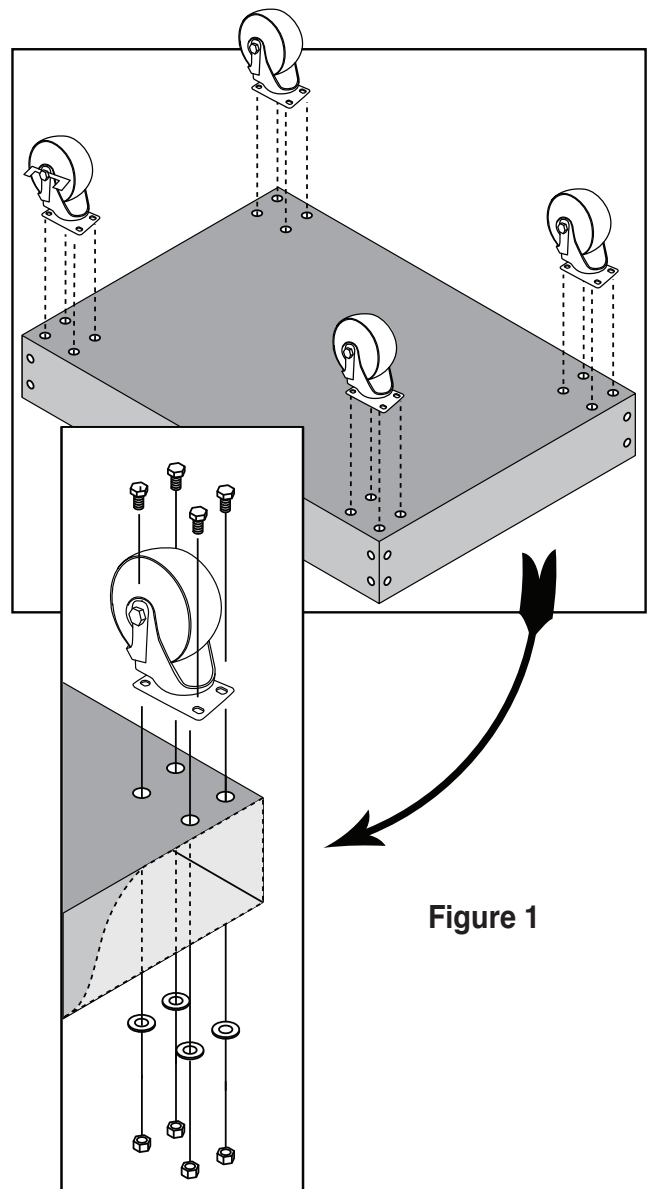


Figure 1

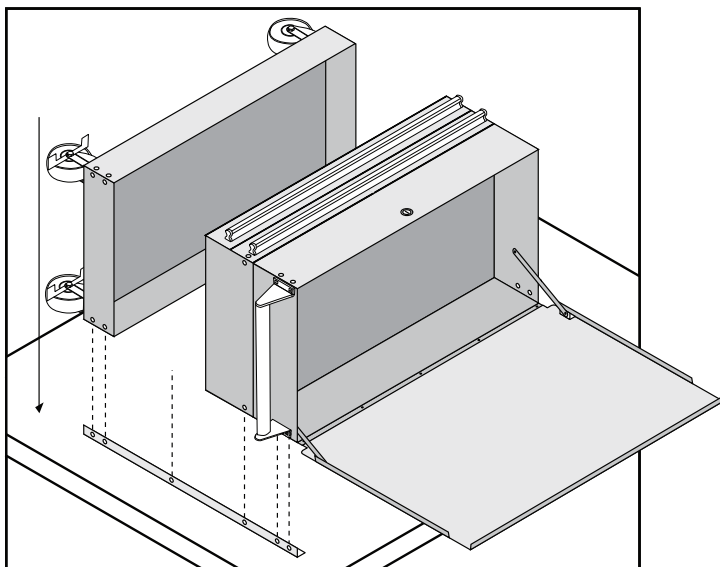


Figure 2

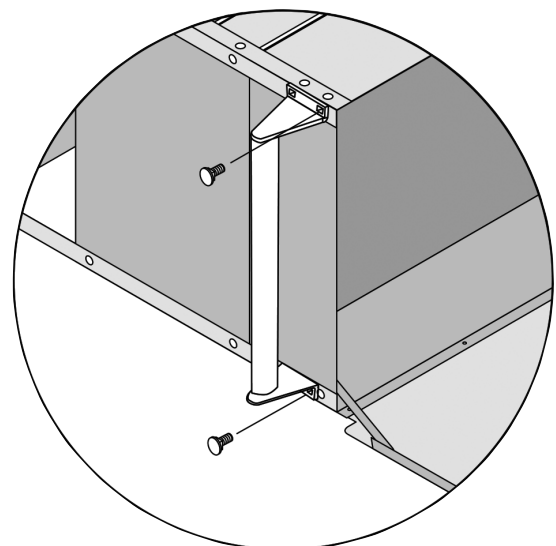


Figure 3

**Assembly Instructions continued**

**Step 4 - Attach Bottom Tray and Drawer Assembly to Legs**

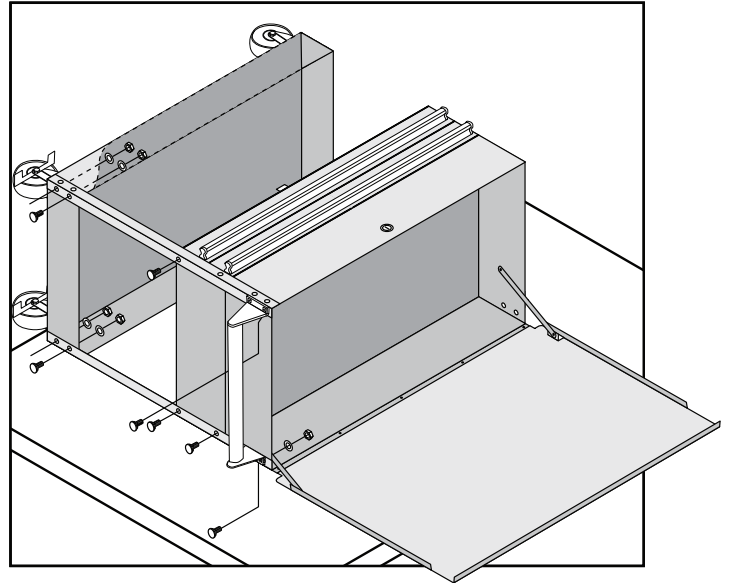
1. Once handle is attached, align holes in legs with matching holes in bottom tray and drawer assembly. See Figure 4.
2. Insert leg bolts through legs and into bottom tray and/or drawer assembly. Secure from the inside with leg washers and nuts until all side holes have been attached and hand tightened.

**Step 5 - Secure Legs**

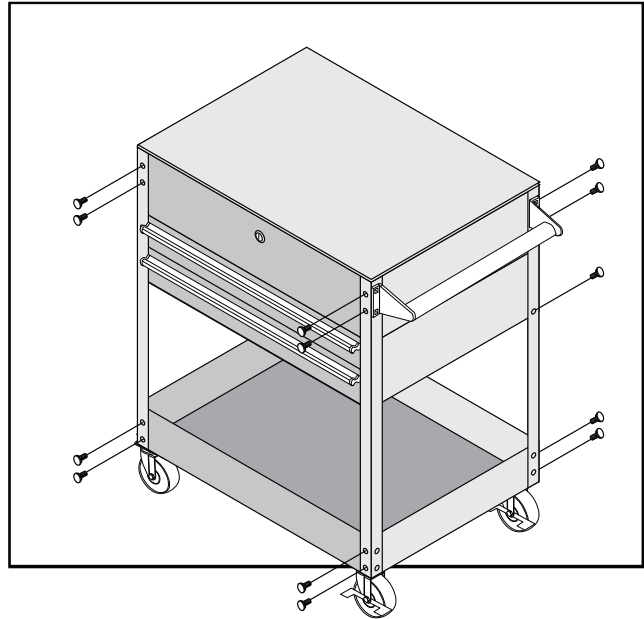
1. Using two people, turn the cart upright.
2. Continue to bolt through aligned holes in front and back of the cart with the leg bolts, washers, and nuts. See Figure 5.
3. Hand tighten bolts. All holes should now be aligned and secured.

**Step 6 - Tighten Bolts**

1. Using a 13 mm wrench and ratchet with a 13 mm socket (or an adjustable wrench), tighten all bolts.
2. Once all bolts are tight, the cart assembly is complete.

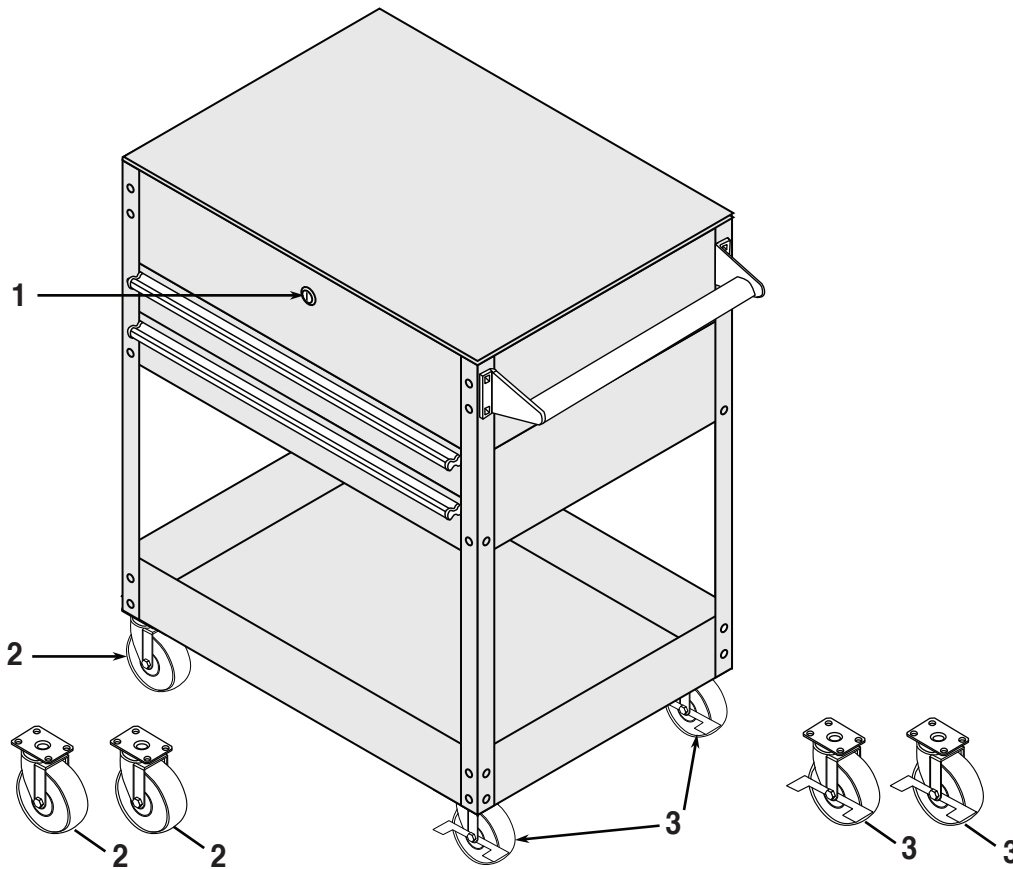


**Figure 4**



**Figure 5**

### Replacement Parts Available



Item No.	Part No.	No. Req'd	Description
1	581332	1	Lock with Keys
2	581329	2	Non-Locking Casters
3	581330	2	Locking Casters
<b>Parts Available But Not Shown</b>			
	581328	2	Gas Shock
	581331	1	Liner Kit for top, drawers, and bottom tray



Get parts at [OTCparts.com](http://OTCparts.com)

This document contains product parts lists and information regarding operation and maintenance. Items listed in the parts list have been carefully tested and selected by OTC. Therefore, use only OTC replacement parts.

Product questions may be directed to the OTC Technical Service Department at (800) 533-6127.