



655 Eisenhower Drive
 Owatonna, MN 55060 USA
 Phone: (507) 455-7000
 Tech. Serv.: (800) 533-6127
 Fax: (800) 955-8329
 Order Entry: (800) 533-6127
 Fax: (800) 283-8665
 International Sales: (507) 455-7223
 Fax: (507) 455-7063

Form No. SP04891611

Parts List &
 Operating Instructions for:

6637

StrutTamer™ II Extreme

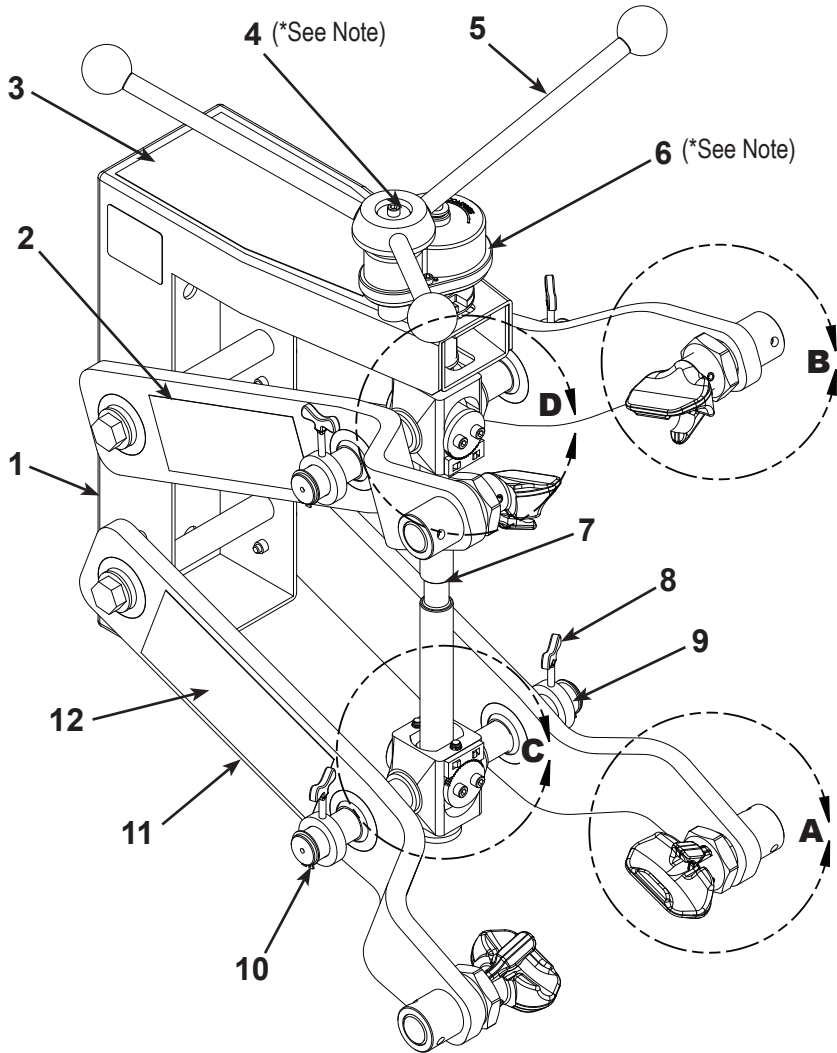

Parts List

Item No.	Part No.	Qty.	Description
1	545543	1	Body
2	576408	2	Decal
3	545274	1	Caution Decal
4	▲	1	Washer
*Hardware for handle is in parts bag.			
5	▲	1	Handle Assembly
6	6587	1	Gear Box
*Use washer and screw from gear box assembly to attach forcing screw.			
7	◆	1	Forcing Screw
8	■	4	Winged Hd. Screw
9	■	4	Retaining Collar
10	★	4	Retaining Ring
11	569810	4	Arm
12	545270	2	Instruction Decal
13	575319	4	Foot
14	569930	4	Locking Finger
15	♣	4	Locknut
16	★	8	Roll Pin (1")
17	◆	1	RH Center Shaft
18	569811	2	Locking Gear
19	569939	2	Trunnion Weldment
20	★	4	Soc. Hd. Cap Screw (1/4-20 x .375 lg.)
21	◆	1	LH Center Shaft

ATTENTION: Before use, remove parts (item 8, 9, and 10) from bag and install on unit as shown in illustration.

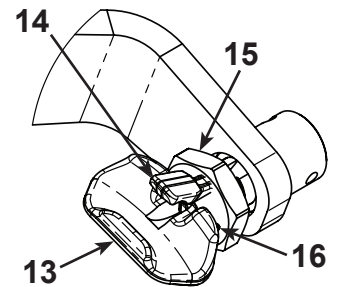

Detail A

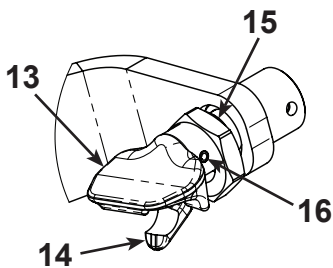

Detail B

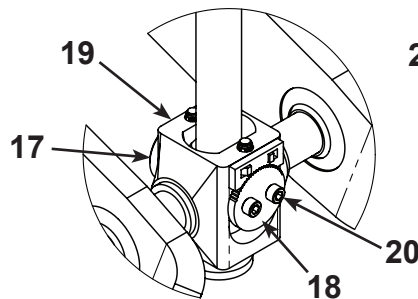

Detail C

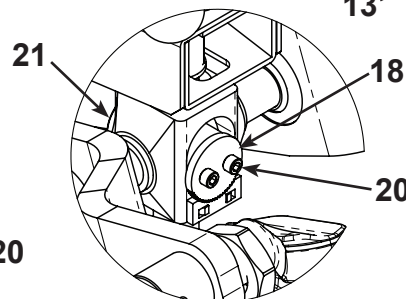

Detail D

Parts List (continued)

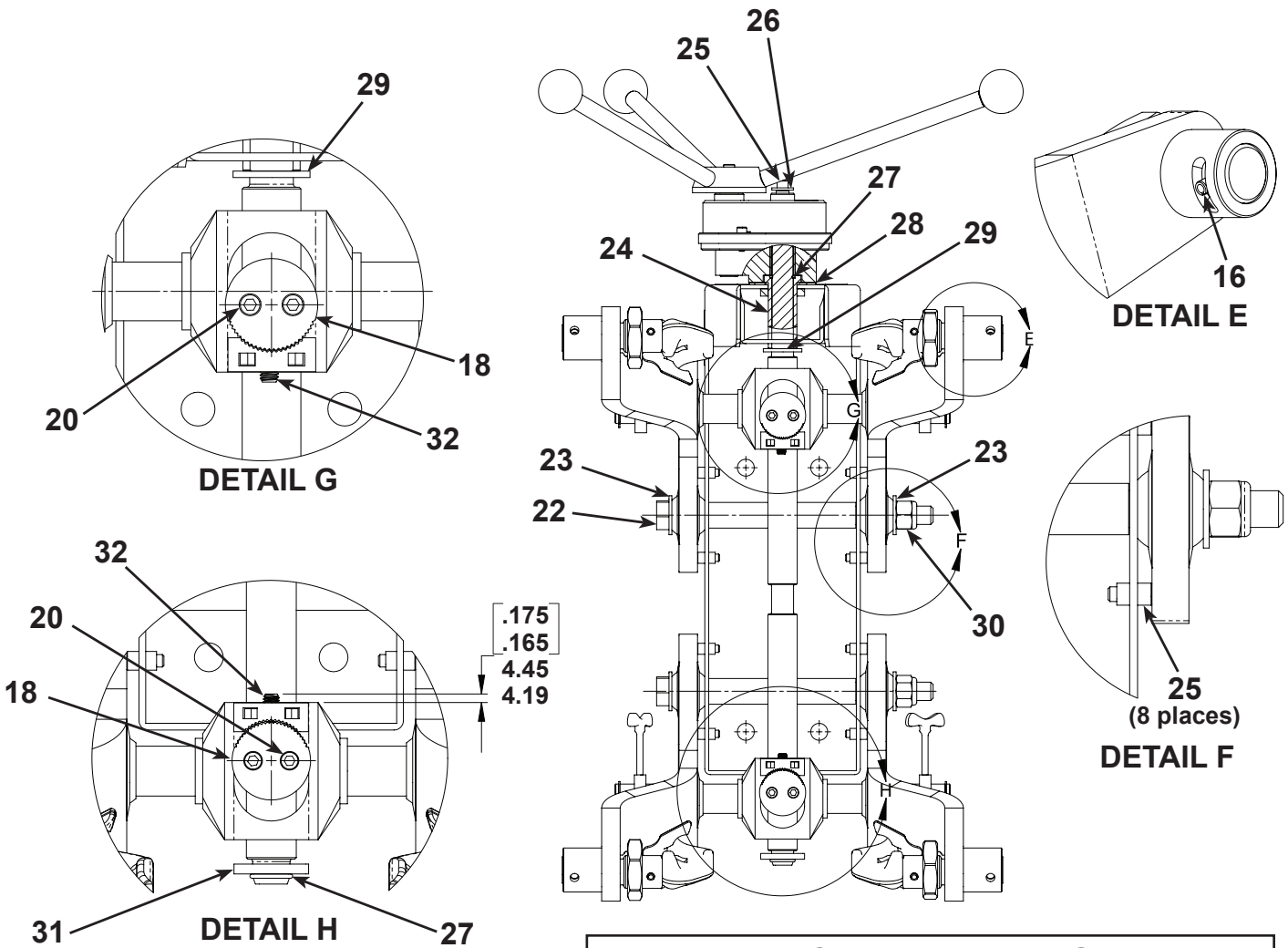

Item No.	Part No.	Qty.	Description
22	★	2	Bolt (5/8-11 x 9")
23	★	4	Washer
24	534689	1	Bushing
25	★	9	Soc. Hd. Cap Screw
26	★	1	Washer (1/4")
27	★	2	Retaining Ring
28	★	1	Nylon Washer
29	★	1	Washer
30	★	2	Nut
31	★	1	Stop Washer
32	+	4	Spring Plunger

REPLACEMENT KIT LEGEND

- ★ = 577446 Hardware Replacement Kit
- ♣ = 577447 Lock Nuts Replacement Kit
- ▲ = 577448 3-knob Handle Replacement Kit
- ⊕ = 577449 Plunger Springs Replacement Kit
- = 577450 Collars Replacement Kit
- ❖ = 577002 Forcing Screw Replacement Kit

This document contains product parts lists and information regarding operation and maintenance. Items listed in the parts list have been carefully tested and selected by OTC. Therefore: Use only OTC replacement parts.

Get parts at
OTCparts.com



Product questions may be directed to
OTC Technical Services at (800) 533-6127.

SAFETY PRECAUTIONS

⚠ WARNING: Spring compression creates a potentially dangerous situation because of the energy stored between the spring mounts. Failure to correctly position the strut assembly in the tool could result in serious injury from a sudden release of strut assembly parts. To prevent personal injury,



- Study, understand, and follow the safety precautions and operating instructions included with the strut spring compressor. If the operator cannot read these instructions, operating instructions and safety precautions must be read and discussed in the operator's native language.
- Wear eye protection that meets ANSI Z87.1 and OSHA standards.
- Use this equipment for automotive strut springs only.
- Check the condition of the strut spring compressor before each use; do not use the equipment if it is damaged, worn, or modified.
- Align the strut assembly before compressing. The spring should be parallel to the forcing screw and on the centerline of the foot support.
- Release and reposition the strut assembly if it is difficult to compress the spring, or if the spring bows.
- Compress the spring only until it is loose in its spring mounts. Stop compressing if the spring or the arms bottom out.
- Do not remove the piston rod nut until the spring is compressed enough to be loose in the mount.

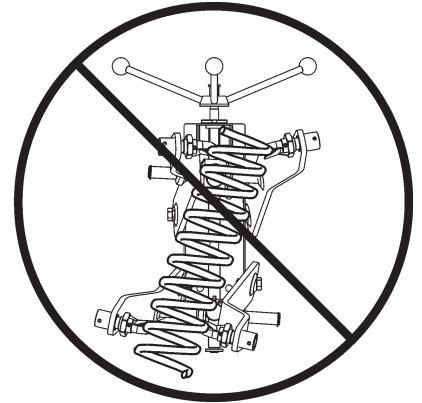

ASSEMBLY

The strut spring compressor may be mounted on a wall, or on an optional mobile stand (part no. 6582).

Use the top two holes in the strut spring compressor body to mount the compressor on the No. 6582 optional stand as shown. (Hardware is included with the stand.)

Use all four holes on the back of the strut spring compressor body to mount the compressor to a wall.

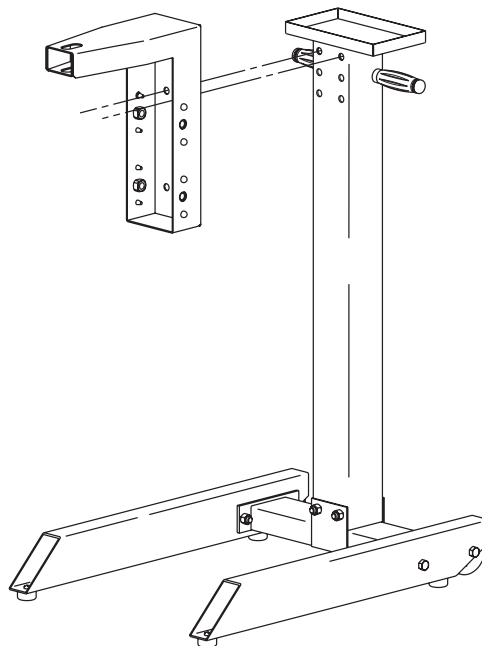

Operating Instructions

Removal

1. Refer to the vehicle service manual, and follow the manufacturer's recommended procedure to remove the strut assembly from the vehicle.
2. Mark the position of the spring in relation to the lower platform and top mount; this notes the correct position for installation.
3. Choose the lowest possible spring coil to insert into the lower left jaw; hand tighten the locknut. See Fig. 1.
4. Load the opposite side of the same coil in the lower right jaw; hand tighten the locknut. *Note: It may be necessary to move the compressor arms to access the coil.*
5. Choose the highest possible spring coil to insert into the upper left jaw; hand tighten the locknut.
6. Load the opposite side of the same coil in the upper right jaw; hand tighten the locknut.

Note: The bridge accessory is designed to be used with the strut spring compressor on strut springs that cannot be compressed enough to remove the retaining nut. Refer to the instructions on the next page.

7. Before servicing the strut assembly, **align the strut spring with the forcing screw** on the strut spring compressor as shown in Figure 1.
8. Equally space the top arms on the top trunnion as shown in Figure 2. The forcing screw must be centered between the two top arms.

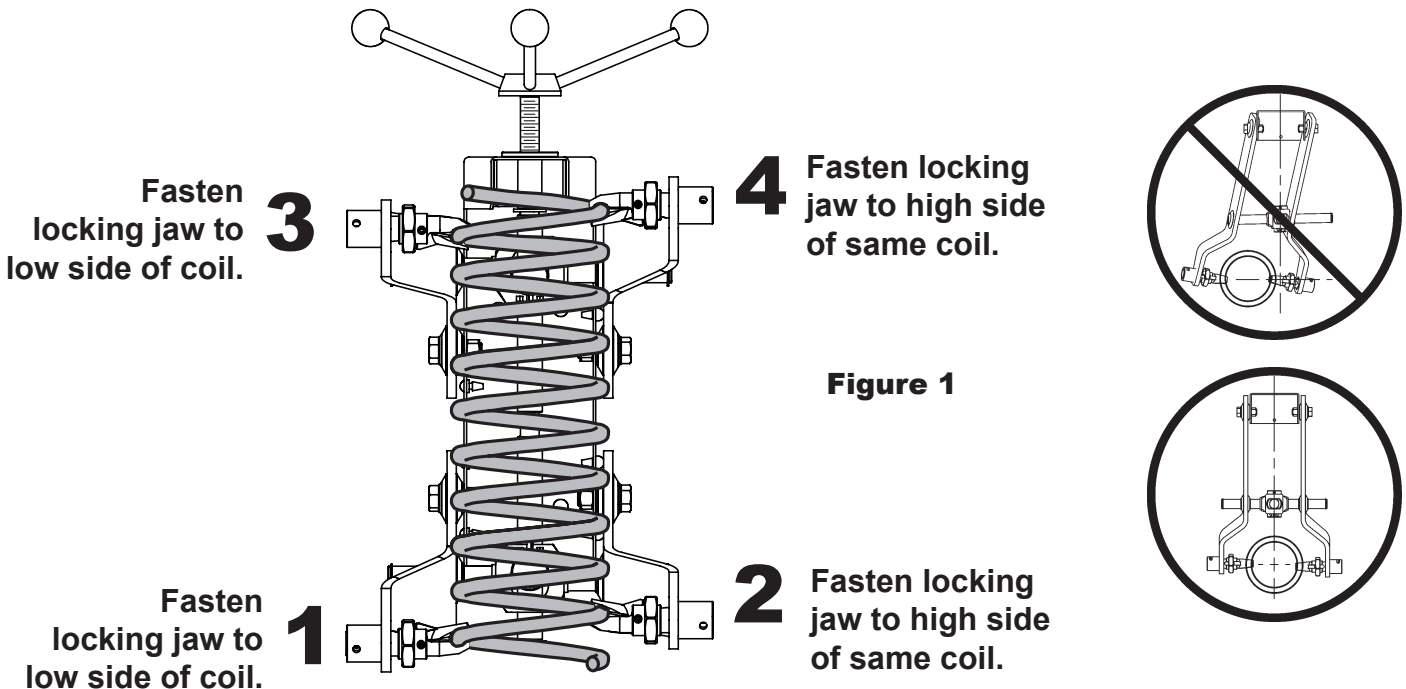

9. Operate the actuating screw to compress the spring only until the strut cartridge is loose in the spring mounts. **IMPORTANT: It is not necessary to over-compress the spring. The spring should be compressed only until the strut tube is loose in the spring.**

10. Remove the piston rod nut, and service the strut as required.

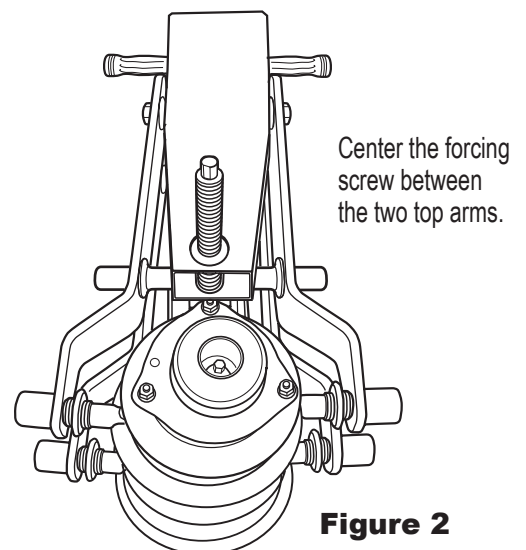

Installation of a New Spring

1. If replacing the spring, remove the old spring from the strut tool. Install the new spring in the tool, assembling the locking jaws as shown in Figure 1. Compress the spring.
2. Align the lower spring tip in its receptacle in the lower platform. Replace the top mount. Attach the piston rod nut, and torque it to the specifications listed in the vehicle service manual.
3. Check the alignment of both spring coil tips to the mounting platforms. Decompress the spring.
4. Follow the manufacturer's procedure to reinstall the strut assembly.

Maintenance

Item numbers refer to the parts list.

1. Use vehicle chassis grease to keep the forcing screw lubricated.

Reassembly Procedure

To repair or replace the forcing screw (Item No. 7), use Replacement Kit No. 577002 and instructions Form No. 577003.