



## TCE 4225



**BOSCH**

**de** Originalbetriebsanleitung  
**Reifenmontiermaschine**

**es** Manual original  
**Máquina para montaje de neumáticos**

**nl** Oorspronkelijke gebruiksaanwijzing  
**Bandenmonteermachine**

**cs** Původní návod k používání  
**Stroj pro montáž a demontáž pneu-  
matik**

**en** Original instructions  
**Tire changer**

**it** Istruzioni originali  
**Smontagomme**

**pt** Manual original  
**Máquina de montagem de pneus**

**tr** Orijinal işletme talimatı  
**Lastik sökme ve takma makinesi**

**fr** Notice originale  
**Machine à monter les pneus**

**sv** Bruksanvisning i original  
**Däckmonteringsmaskin**

**pl** Instrukcja oryginalną  
**Zmieniacz opon**

**zh** 原始的指南  
**轮胎装配机**

# Contents

<b>1. Symbols Used</b>	<b>23</b>	<b>6. Maintenance</b>	<b>36</b>
1.1 Documentation	23	6.1 Suggested lube	36
1.2 TCE 4225	23	6.2 Cleaning and servicing	36
1.3 Additional adhesive tags	23	6.2.1 Maintenance intervals	36
		6.2.2 Condensate removal	36
		6.2.3 Nebulizer oil refill	36
		6.2.4 Change oil in the oil nebulizer	36
<b>2. Operator instructions</b>	<b>24</b>	6.3 Spare and wearing parts	37
2.1 Important information	24		
2.2 Safety information	24	<b>7. Decommissioning</b>	<b>37</b>
2.3 Electromagnetic compatibility (EMC)	24	7.1 Place change	37
		7.2 Temporary decommissioning	37
<b>3. Product description</b>	<b>24</b>	7.3 Disposal	37
3.1 Expected use	24		
3.2 Requirements	24	<b>8. Technical data</b>	<b>38</b>
3.3 Delivery specification	24	8.1 TCE 4225	38
3.4 Special accessories	24	8.2 Dimensions and weights	38
3.5 Description of unit	25	8.3 Reach	38
3.6 Description of function	25	8.3.1 Car wheels	38
		8.3.2 Motorcycle wheels	38
<b>4. Initial commissioning</b>	<b>26</b>		
4.1 Unpacking	26	<b>9. Glossary</b>	<b>38</b>
4.2 Assembly	26		
4.2.1 Cover removal	26		
4.2.2 Lifting of the tilting column	26		
4.2.3 Column fixing	27		
4.2.4 Positioning the vertical rod	27		
4.2.5 Mounting the bead breaker arm	28		
4.2.6 Mounting of the inflation device for tubeless tires	28		
4.2.7 Machine positioning	29		
4.3 Pneumatic connection	30		
4.4 Electrical connection	30		
4.5 Check rotation direction	30		
<b>5. Operating instructions</b>	<b>31</b>		
5.1 Tire demounting	31		
5.1.1 Preparations for demounting	31		
5.1.2 Demounting	32		
5.2 Tire mounting	32		
5.2.1 Mounting preparations	33		
5.2.2 Mounting	33		
5.3 Inflation	34		
5.3.1 Inflation with inflation pipe	34		
5.3.2 Inflation with tubeless pneumatics devices	34		
5.4 Functioning anomalies	35		

# 1. Symbols used

## 1.1 Documentation

Pictograms linked with the key words Danger, Warning and Caution are warnings and always indicate an immediate or potential hazard to the user.



**Danger!**

Immediate danger that could cause serious personal injury or death.



**Warning!**

Potentially dangerous situation that could cause serious personal injury or death.



**Caution!**

Potentially dangerous situation that could cause personal injury or damage to property.

**!** **Important** – warns of a potentially hazardous situation in which the TCE 4225, the test sample or other object in the vicinity could be damaged.

In addition to these warnings, the following symbols are also used:

**i** **Info** – In addition to these warnings, the following symbols are also used.

➤ **Single-step procedure** – instructions for a procedure that can be completed in just one step.

⇒ **Intermediate result** – an intermediate result is displayed during a procedure.

➔ **Final result** – the final result is displayed at the end of the procedure.

## 1.2 TCE 4225



**Disposal**

Old electrical and electronic devices, including cables and accessories or batteries must be disposed of separate to household waste.

## 1.3 Additional adhesive tags

**!** Respect all the safety instructions and danger warnings on the products and keep the related tags in full readable conditions!



**Mounting tool**

Danger of crushing the fingers between the mounting tool and the rim.



**Mains tension**

Danger of electrical shock when touching the parts of the electrical system.



**Bead breaker**

Danger of crushing the limbs between the bead breaker and the tire.

## 2. User information

### 2.1 Important notes

Important information on copyright, liability and warranty provisions, as well as on equipment users and company obligations, can be found in the separate manual "Important notes on and safety instructions for Bosch Tire Equipment". These instructions must be carefully studied prior to start-up, connection and operation of the TCE 4225 and must always be heeded.

### 2.2 Safety instructions

All the pertinent safety instructions can be found in the separate manual "Important notes on and safety instructions for Bosch Tire Equipment". These instructions must be carefully studied prior to start-up, connection and operation of the TCE 4225 and must always be heeded.

### 2.3 Electromagnetic compatibility (EMC)

The TCE 4225 is a class A product as per EN 61 326.

## 3. Product description

### 3.1 Expected use

TCE 4225 is a modern tire-changer for use on cars. With the aid of relevant accessories, it can also be used on motorcycles.

 TCE 4225 has to be used exclusively for the specified purpose and only in the functioning scope shown in these instructions. Any other use different from that specified has to be considered improper and therefore not allowed.

 The manufacturer is not liable for any damage caused by improper use.

### 3.2 Requirements

TCE 4225 has to be installed on an even surface made of concrete or similar materials, and has to be firmly anchored. A pneumatic connection is requested.

### 3.3 Delivery specification

Denomination	Order code
TCE 4225	
Bead lifting lever	1 695 102 683
Brush	1 695 100 123
Inflation manometer	1 695 103 996
Protection tab	1 695 101 608
Mounting tool cover	1 695 102 725
Bulb container	1 695 103 968
Bulb container support	1 695 104 083

### 3.4 Special accessories

Denomination	Order code
Bead locking clamp	1 695 103 302
Upper wedge	1 695 103 216
Motor adaptors for 20" plate	1 695 105 438
Scooter adaptors for 20" plate	1 695 105 440
Roller	1 695 900 005
Object holder	1 695 900 003
Bead pressing device	1 695 103 261
20" motor bead breaker support	1 695 103 252
Motor tool kit	1 695 103 210
Bead breaker blade protection	1 695 102 090
Aisles protections for 20" plate	1 695 105 083
Tool tab protections (5 pieces)	1 695 101 608
TCE 200	1 695 900 002
Wheel hoisting device	1 695 900 025

### 3.5 Description of unit



On the TCE 4225 there are rotating and moving parts that could injure fingers and arms.

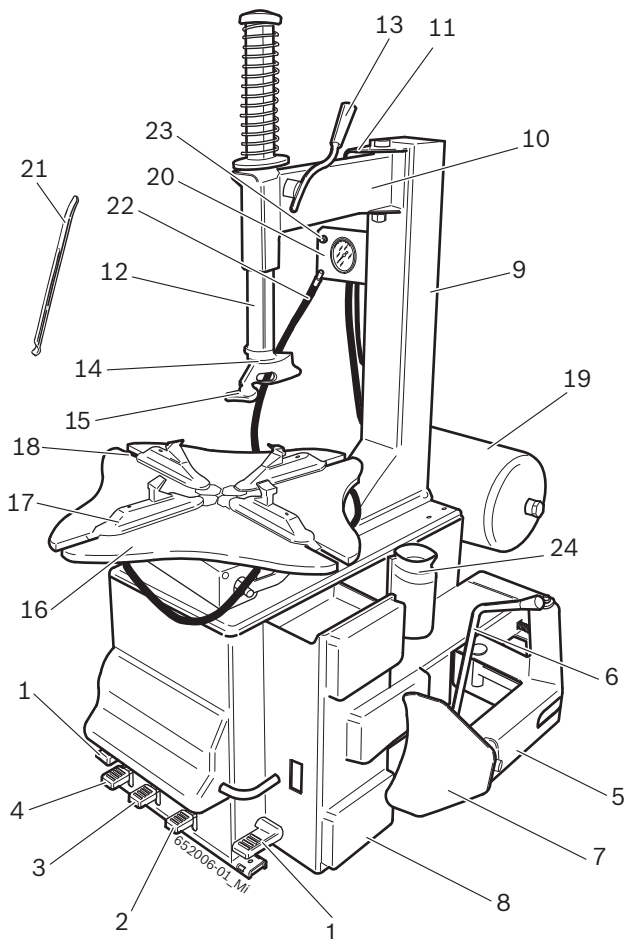

Fig. 1: TCE 4225

### 3.6 Description of function

Below are reported the main functions of the listed components of the TCE 4225:

- Pedal box, comprehends control pedals of the equipment (locking flange rotation pedal, bead breaking pedal, locking jaws pedal, inflation pedal).
- Bead breaker, for the bead breaking of the tire from the rim; it is made of the bead breaking arm pneumatically operated by a double effect cylinder, lever for the arm positioning, antiabrasive supports for rim support during bead breaking phases.
- Column switch group, made up of a column switch which supports the components necessary to dismantle (and re-assemble) the tire from the rim: flag horizontal arm (with locking knob), vertical sliding rod (with locking lever), mounting tool to dismantle (and re-assemble) the tire from the rim, with the aid of the bead lifting lever.
- Locking plate, locking and rotation device (clockwise and counter-clockwise) of the rim, pneumatically driven by 2 cylinders, made of 4 movable lanes with locking jaws for the internal and external locking of the rim.
- Automatic inflation device for tubeless tires, made by a compressed air circuit and an instantaneous opening valve operated by the inflation pedal (the air comes out from holes on the jaws, in order to seat perfectly the bead of a tubeless tire).

Pos.	Name	Function
1	Locking flange rotation pedal	Locking plate rotation: <ul style="list-style-type: none"> <li>• clockwise (press down the pedal).</li> <li>• counter-clockwise (lift the pedal from bottom to top).</li> </ul>
2	Bead breaker pedal	Bead breaking arm activation.
3	Locking jaw pedal	Opening and closing of the locking plate jaws.
4	Inflation pedal	Operation of the automatic inflation device for tubeless tires and inflation pipe.
5	Bead breaking arm	Bead breaking of the tire from the rim.
6	Bead breaking arm lever	Positioning of the bead breaker blade.
7	Bead breaker blade	Tire pressing for bead breaking operation.
8	Antiabrasive supports	Tire support for bead breaking operations.
9	Column	Horizontal jib arm and mounting tool support.
10	Cantilever horizontal arm	Horizontal positioning of the mounting tool.
11	Locking knob	Cantilever arm locking.
12	Vertical sliding rod	Vertical positioning of the mounting tool.
13	Locking lever	Locking of the vertically sliding rod.
14	Mounting tool	Mounting and demounting of the tire from the rim (with the help of the bead lifting lever).
15	Sliding roller	Inserted in the mounting tool compartment, to avoid any friction between the rim and mounting tool during the tire dismantling and assembly phases For the alloy rims, a special plastic protection is arranged.

Pos.	Name	Function
16	Locking plate	Locking and rotation of the rim.
17	Movable lanes	Positioning of the locking jaws. Tubeless tire inflation.
18	Locking jaws	Internal or external locking of the rim.
19	Compressed tank	Inflates tubeless tires. Inflation is achieved through high pressure blowing that positions the tire bead on the rim edge. The air tank (compliant to UE 87/404) has a capacity of 18 litres of compressed air.
20	Inflation gauge	Tire inflation check. The manometer is compliant to CEE 87/217 directive.
21	Bead lifting lever	Lifting of the tire edge in demounting and mounting phases.
22	Inflation pipe	Tire inflation.
23	Deflation button	Tire deflation.
24	Lubricator holder bulb	Mounting paste container support

## 4. Initial commissioning

### 4.1 Unpacking

1. Remove the tape and the fixing clamps from the pallet and the packaging cardboard.

 After unpacking check the integrity of TCE 4225 and check that no components are visibly damaged. In case of doubt do not proceed to start-up and contact a qualified technician and/or your vendor.

2. Take out of the transport crate the standard accessories and the packaging materials.

 Dispose correctly of packaging material, hand it over to the designated collection points.

### 4.2 Assembly

#### 4.2.1 Cover removal

1. Unscrew the 4 screws of the side cover and remove the cover itself.

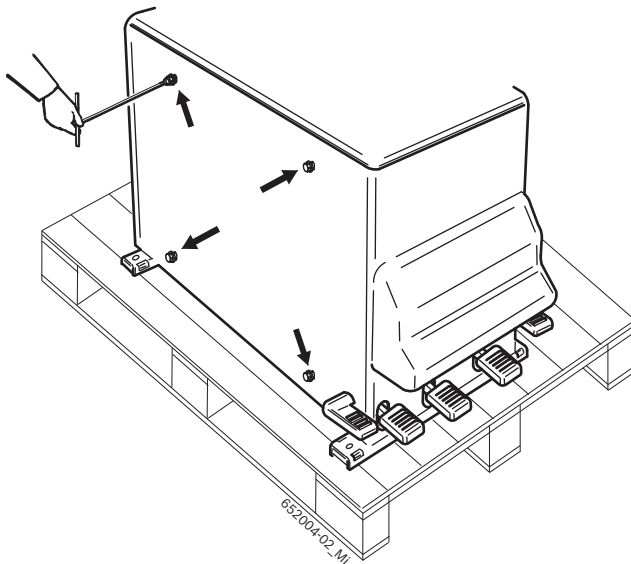

#### 4.2.2 Lifting of the tilting column

1. Get a 1 Mt lifting sling, DR 50 model (safety factor 6:1); wrap the sling around the cantilever arm and lift the column with a hoist.

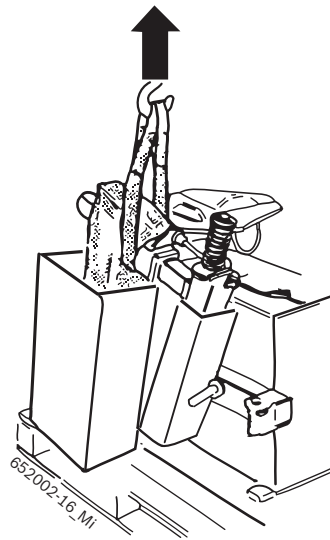

2. Lean the column on the casing.

### 4.2.3 Column fixing

1. Fix the column to the casing with the screws contained in the provided accessories box.

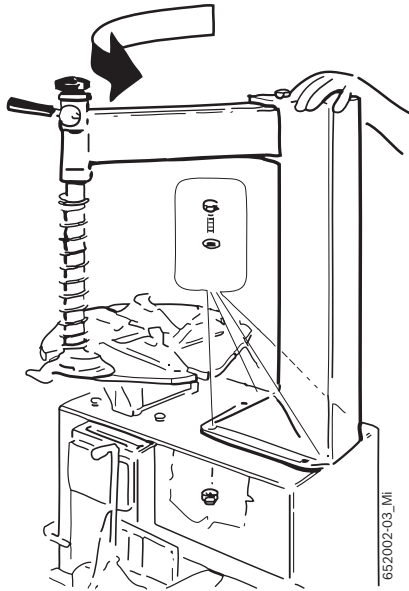

### 4.2.4 Positioning the vertical rod

1. Use the locking lever to unlock the vertical rod (1), lift by about 10 cm and block it again.
2. Unscrew the cap on top of the rod with a wrench (2).

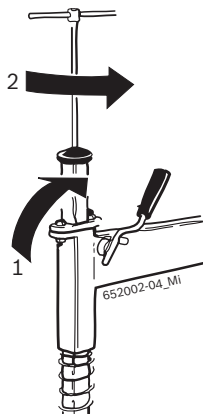

**!** Warning: when unlocking the rod keep a hand underneath it.

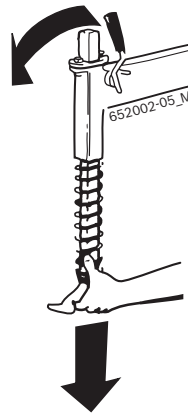

3. Remove the rod; remove the spring and put again the rod in its original seat, locking it at the end stop.
4. Insert the spring in the upper part of the rod and screw again the cap with the wrench.



#### **Danger!**

The spring could eject violently the rod from its housing, thus it might be a serious danger for the operator.

➤ Carry out this operation carefully.

#### 4.2.5 Mounting the bead breaker arm

1. Remove the external elastic ring and take off the hinge rod from its housing in the bead breaking arm.
2. Remove the self locking nut.
3. Insert the bead breaking arm and centre the joint pin with the bead breaking cylinder, ensuring that the flat part of the joint pin (1) is facing the outside.

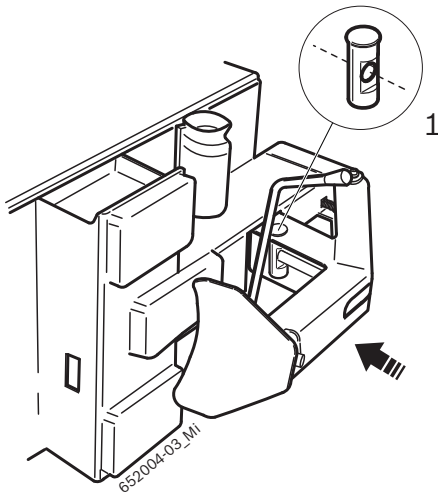

4. Insert the hinge-pin and put back in place the external elastic ring.
5. Place the buffer spring on the provided tab and screw in the bead breaking cylinder the self locking nut.



**Danger!**  
 Wrong mounting of the bead breaking cylinder compromises machine functioning and can be a serious danger for the operator.  
 ➤ During machine installation be sure that the nut is correctly screwed in the bead breaking cylinder rod (at least 10 mm).

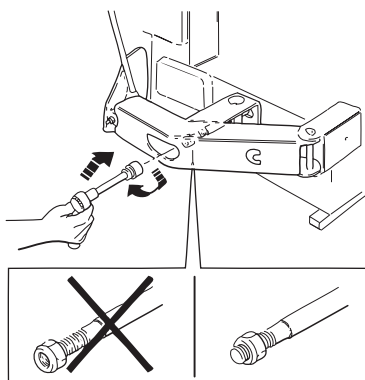

#### 4.2.6 Mounting of the inflation device for tubeless tires

1. Install the air tank behind the column by fitting the 2 provided screws.

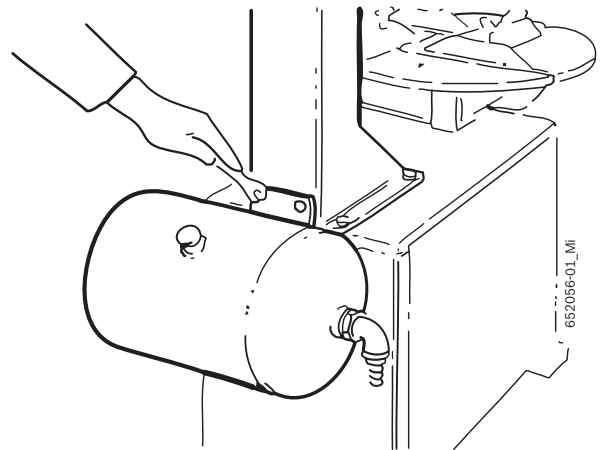

2. Insert the rubber pipe in the tank joint and fasten the hose clamp.

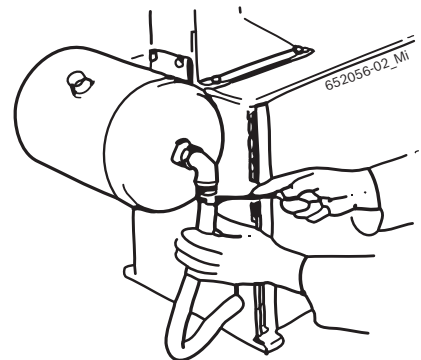

3. Connect the gauge support to the column with the 2 provided screws.

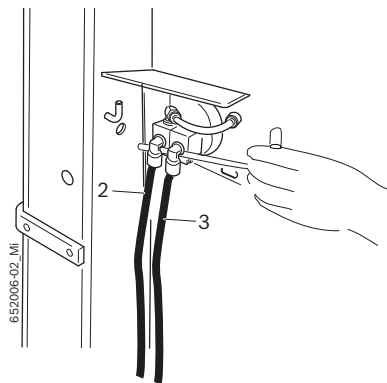



4. Connect the supply pipes of the tank to the joint located in the lower part of the tank (1).
5. Connect the air pipes to the rapid joints of the manometer, by inserting them in the appropriate holes: the pipe coming from the front joint of the inflation pedal (1) in the internal joint (nearer to the column), the pipes coming from the rear joint of the inflation pedal (2) in the external joint.

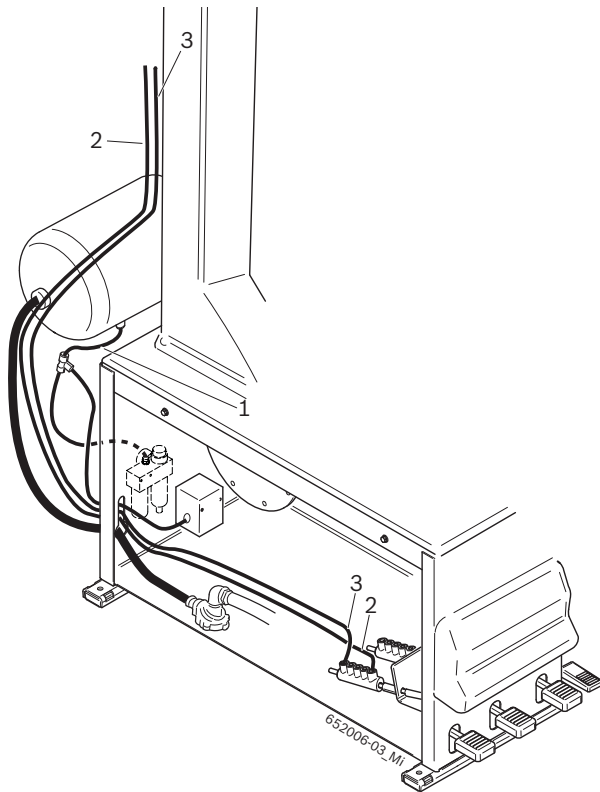

#### 4.2.7 Machine positioning

1. Put back in place the side door.
2. Loosen the two screws that fix TCE 4225 to the pallet.

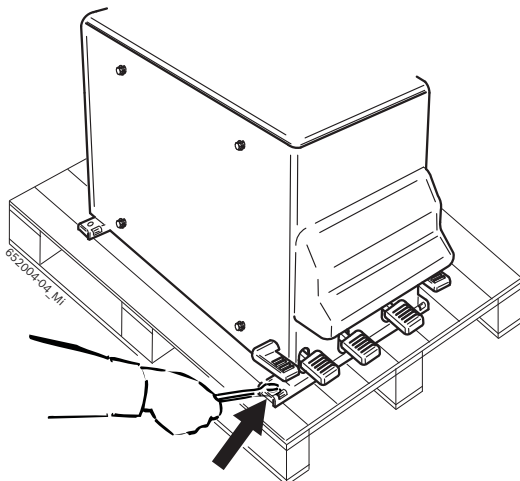

#### Warning - damage risk!

The lifting belts can crush the flexible supply pipes of the cylinder or damage the applied parts of the TCE 4225.

➤ Insert the lifting belts carefully.

3. Insert the appropriate lifting belts (length belt 1: 1 Mt, belt 2: 3 Mt), with sufficient capacity, as shown.

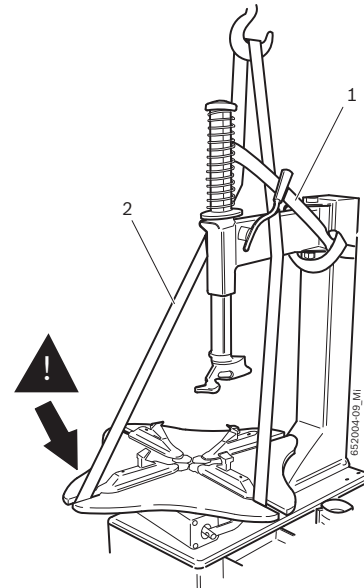



#### Warning - tilting danger!

The barycentre of the TCE 4225 does not lie in its centre.

➤ It is necessary to lift the machine slowly.

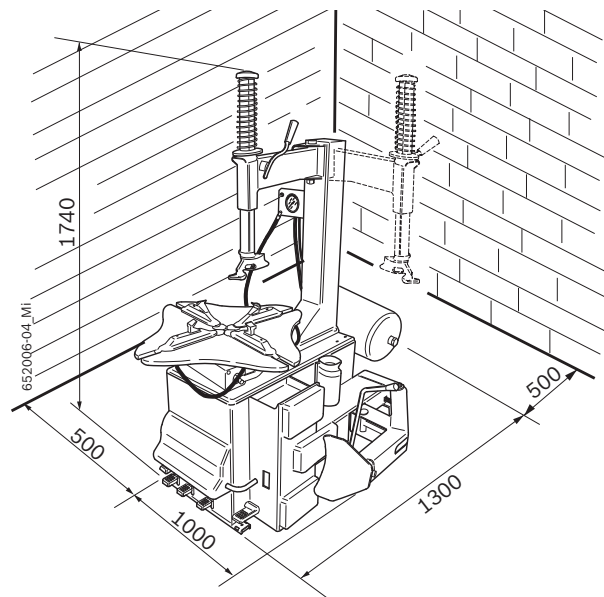
4. Lift the TCE 4225 with a lift crane and install it in the designed area respecting the minimum distances  $s$  shown in the picture.



 For safe and ergonomic use of the TCE 4225 it is recommended to leave a minimum of 500 mm space from surrounding walls.



#### Warning - tilting danger!

During the functioning of TCE 4225 considerable forces are exerted.

- The TCE 4225 has to be fixed in at least 3 points on the floor (screw holes see chap. 4.2).

 In each screw hole are placed shock absorbers to reduce vibrations to the minimum.

5. Pre-arrange a suitable lubricator in the lubricator holder bulb.

### 4.3 Pneumatic connection

1. Connect the TCE 4225 to the compressed air supply unit.

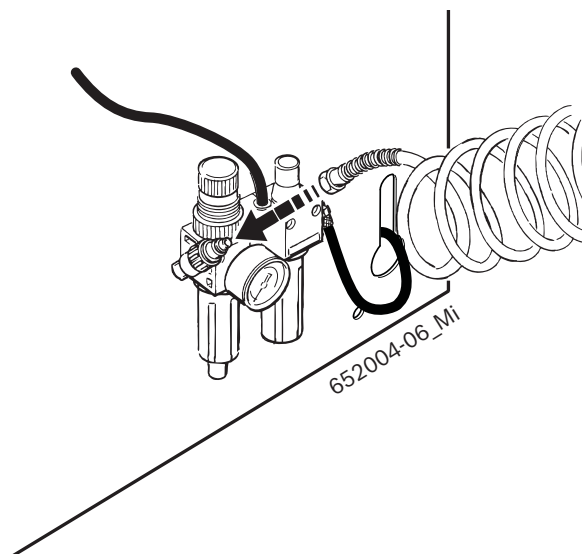

2. Adjust to a pressure between 8 and 12 bar.
  - ⇒ Pull the red knurled screw (pressure reducing valve) first upwards and then twist it to adjust operating pressure.
  - ⇒ Check pressure on the manometer.

### 4.4 Electrical connection

1. Check the correspondence of the mains tension and the tension shown on the identification tag.
2. Ask a qualified electrician to mount a connection plug for single-phase or (depending on the tension you have ordered ) three-phase current (see the electrical connections diagram inside the electrical panel).

 The costs of arranging a mains protection device for the plug are borne by the customer.

3. Protect the TCE 4225 according to specific national rules.

### 4.5 Check rotation direction

 For a correct functioning of TCE 4225 it is extremely important that, when the locking flange pedal shown in Fig. 2 (1) is pressed, the locking flange (Fig. 2) rotates clockwise.

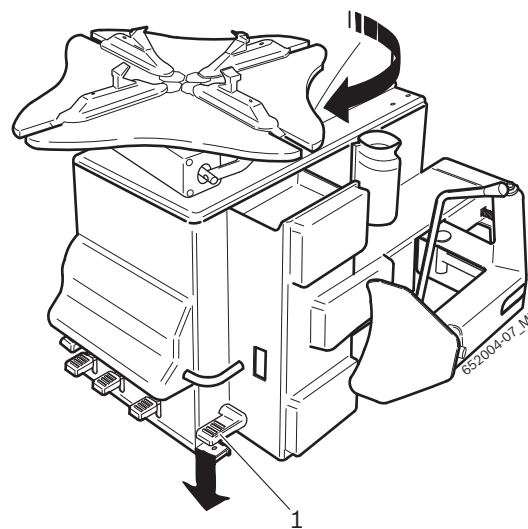

Fig. 2: Check rotation direction.

## 5. Operating instructions



### Warning - tire or rim damage danger!

Excessive pressure can e. g. result in cracks (on the inside/outside) of the tire. The rim can be scratched or deformed.

- Read the Wdk publications available in German and English! ([www.wdk.de](http://www.wdk.de): mounting/demounting instructions – criteria catalogue)
- Inner temperature of the tire must be at least 15 °C (only in case of RFT/UHP).
- Read the Wdk publications available in German and English! ([www.wdk.de](http://www.wdk.de): mounting/demounting instructions – tire overheating)
- Adjust pressure to the type of tire.
- Use the plastic protections on the types of rim that need it.

! Before demounting or mounting operations it is extremely important to collect all the rim and tire data. In this way it will be possible to know in advance the mounting, the pressure and the required accessories!

i Remove all the balancing weights from the rim.

i If the semi drop centre of the rim is placed in the inside part it is necessary to insert a cover to the locking jaws (see chap. 3.3) on the flanged plate, because in this case the rim leans on its side during rotation.

### 5.1 Tire demounting

i Read the Wdk publications available in German and English! ([www.wdk.de](http://www.wdk.de): mounting/demounting instructions).

#### 5.1.1 Preparations for demounting

! Avoid valve damage!

1. Pull out the needle from the valve.
  - ⇒ The air is discharged completely from the tire.
2. Place the wheel on the floor, close to the antiabrasive supports of the beadbreaker; to put the blade (1) close to the bead pressing the bead breaker control pedal (2). The operation has to be carried out in different points of the wheel (rotating it manually) until the bead doesn't come off completely.

i Lubricate the side of the tire and the hump with mounting paste to make the bead breaking operations easier.

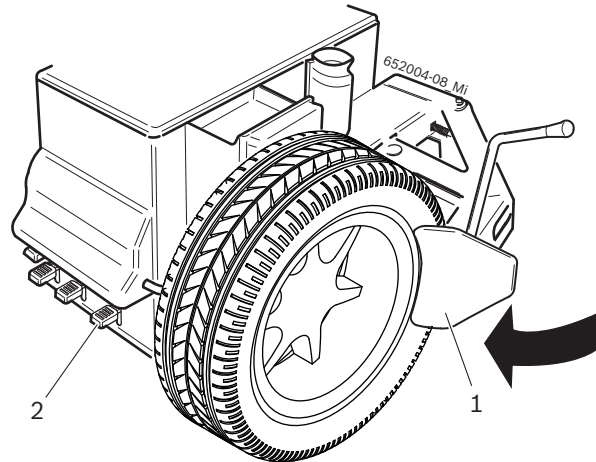

3. Repeat the operation on the opposite side of the wheel.



### Warning – limb injury danger!

During operation of the bead breaking arm, be careful in order to avoid that the limbs are not crushed between the tire and the bead breaker.

- Do not insert limbs between the tire and the bead breaking arm.



### Warning – damage risk for RFT or UHP tires!

Cracks in case of operation on cold tire. Tire explosion in case of high speed.

- Inner temperature of the tire must be at least 15 °C.
- Read the Wdk publications available in German and English! ([www.wdk.de](http://www.wdk.de): mounting/demounting instructions – tire overheating)
- Before mounting put the tire in a temperate room.

### 5.1.2 Demounting



#### Warning – hand injury danger!

During locking plate rotation there is a risk of crush injuries.

- Do not insert the fingers between the tire and the rim.

1. Turn counterclockwise the locking knob to unlock the sliding rod.
2. For external locking of the rim press the locking jaws opening pedal to prepare the jaws in the open position;

 In case of internal locking the jaws must be prepared in the closing position.

3. Place the wheel on the locking plate
4. Exerting with the hand a pressure on the rim, press the locking jaws closing pedal in order to lock it.
5. Lubricate with mounting paste the side of the tire till the edge of the rim.
6. Bring the mounting tool close to the rim until the roller touches the edge of the rim.

 Lift the locking lever of the vertical rod to carry out vertical spacing of the mounting tool and arm blocking

 Use the locking knob of the horizontal arm to adjust mounting tool spacing from the tab (the recommended spacing is 3 mm).

7. Insert the bead breaking lever between the mounting tool and the bead of the rim. To make this operation easier bring the bead in the part opposite to the mounting tool inside the semi drop centre of the rim.

 In case RFT or UPH tires the use of accessories like clamps, wedge or of the TCE 200 bead breaker is suggested.

8. With the provided bead breaking lever lift the edge of the tire and lean it on the mounting tool tab (1).

9. Press the rotation pedal to rotate clockwise the locking plate, until complete ejection of the bead from the rim.

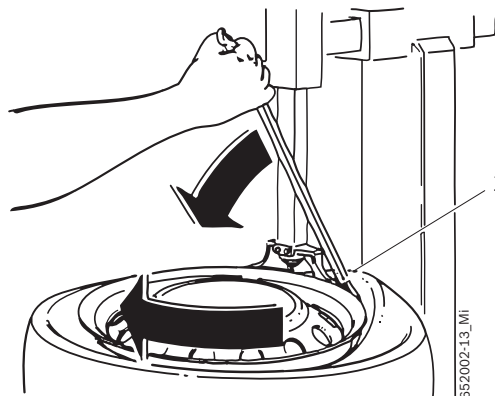

 In case of tires with tube, use the locking knob to unlock the horizontal arm and move it to free the working area and extract the tube.

10. Repeat the same operations to make the second bead come out.

### 5.2 Tire mounting



#### Danger of car accidents caused by damaged rims or tires!

In case of tire or rim damage during mounting dangerous or even lethal situations may occur during driving.

- The operator has to be specifically trained.
- Do not exert excessive forces on the tire or the rim, adjust the slow rotation speed.
- Use a sufficient quantity of mounting paste.
- In case of anomalies, e.g. suspicious noises, stop mounting immediately.
- For mounting of critical rim/tire combinations, read the Wdk publications available in German and English! ([www.wdk.de](http://www.wdk.de): mounting/demounting instructions – criteria catalogue).

### 5.2.1 Mounting preparations



#### Warning – damage risk for RFT or UHP tires!

Cracks in case of operation on cold tire. Tire explosion in case of high speed.

- Inner temperature of the tire must be at least 15 °C.
- Read the Wdk publications available in German and English! ([www.wdk.de](http://www.wdk.de): mounting/demounting instructions – tire overheating)
- Before mounting put the tire in a temperate room.

1. Lubricate with mounting paste the inside of the rim in correspondence of the edge and of the shoulder of the rim and of the semi drop centre.
2. Lubricate the two tire beads with mounting paste.
3. Lean the tire oblique on the rim.

### 5.2.2 Mounting



#### Warning – hand injury danger!

During locking plate rotation there is a risk of crush injuries.

- Do not insert the fingers between the tire and the rim.

1. Rotate the locking flange and bring the valve between 2 o'clock and 4 o'clock position (the mounting tool is at 12 o'clock position).
2. Bring the mounting tool close to the rim until the roller touches the edge of the rim.

**i** Lift the locking lever of the vertical rod to carry out vertical spacing of the mounting tool and arm blocking

**i** Use the locking knob of the horizontal arm to adjust mounting tool spacing from the tab (the recommended spacing is 3 mm).

3. Lay the tire bead on the lower left edge of the mounting tool tab.

4. While holding the bead in the semi-drop centre press the rotation pedal and keep turning the locking plate until the upper tire bead has passed close to the mounting tool (1) and it has gone under the edge of the rim.

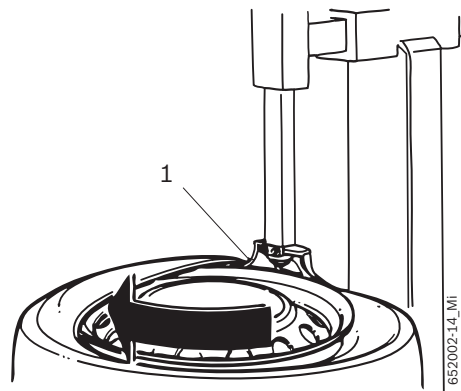

**i** Be sure that the bead is inserted in the drop centre of the rim in order to eliminate bead yields; in order to make his operation easier, it is suggested, during rotation of the locking plate, to assist with a bit of pressure the insertion of the bead in the rim.

**i** In case of tires with tube, use the locking knob to unlock the horizontal arm and move it to free the working area; place the rim so that the valve hole of the tube is positioned at about 90° degrees relatively to the mounting tool position and insert, if needed, the tube.

5. Repeat the same operations for the insertion of the second bead.

**i** In case of RFT or UPH tires, in order to hold the bead inside the semi drop centre, the use of accessories like clamps, wedges or of the TCE 200 bead breaker is suggested.

6. Press the locking jaw pedal to release the rim.

---

## 5.3 Inflation

---



Inflation can generate potential danger situations. The operator has to carry out the necessary precautions in order to guarantee operational safety.

---

### ! **Safety device:**

To protect the operator from eventual dangers that can occur during tire inflating on the locking plate, the TCE 4225 has been equipped with a **valve that limits operational pressure to 3,5 bar**.

### 5.3.1 Inflation with inflation pipe

1. Screw the valve element.
2. Connect the inflation pipe to the tires' valve.
3. Operate on the inflation pedal to inflate the tire until it reaches the nominal pressure.

### 5.3.2 Inflation with tubeless pneumatics devices

1. Insert the inflation pipe in the tire valve.
2. Lift the tire upwards with both hands, allowing the air (that comes out from the holes in the jaw) to come in between rim and tire.
3. Press the inflation pedal until end stop, to let the air come out from the jaws and, in the meantime, release the tire to allow bead seating.

! If the tire bead doesn't "seat" repeat accurately the above mentioned operations.

4. Once the tire bead is seated, carry on the inflation operation by holding the inflation pedal pressed in its intermediate position, until the desired pressure is reached.

## 5.4 Functioning anomalies

In the following table all the possible anomalies and their correspondent remedies are listed.

Other supposable functioning anomalies are mainly of technical nature and have to be verified and resolved by qualified technicians.

In any case contact the assistance service of the authorized vendor of Bosch equipment.

 To speed up intervention it is important to tell during the phone call the data reported on the identification plate (tag on the back of the TCE 4225) and the type of malfunction.

 Any intervention on the electrical, hydraulic or pneumatic system, has to be performed exclusively by qualified technicians which are properly trained.

Anomalies	Causes	Remedies
The locking plate does not turn in any of the two directions.	<ol style="list-style-type: none"> <li>1. The network plug is not connected.</li> <li>2. The network plug is not correctly connected.</li> <li>3. The tension does not correspond to the prescribed value.</li> </ol>	<ol style="list-style-type: none"> <li>1. - 2. Check if the network plug is correctly inserted in the socket and check connection.</li> <li>3. Check the tension of tension.</li> </ol>
When the locking flange pedal is pressed down, the locking plate turns clockwise.	<ol style="list-style-type: none"> <li>1. Phases inversion during plug connection.</li> </ol>	<ol style="list-style-type: none"> <li>1. Invert the 2 phases in the network plug (qualified electrician is required).</li> </ol>
The locking plate transmits insufficient torque (low force).	<ol style="list-style-type: none"> <li>1. Wrong network tension.</li> <li>2. Wrong phases connection in the plug.</li> <li>3. Loosen transmission belt.</li> </ol>	<ol style="list-style-type: none"> <li>1. Check the correspondence of the network tension and the tension shown on the identification plate.</li> <li>2. Check that the phases in the plug are correctly connected.</li> <li>3. Pull the transmission belt.</li> </ol>
The locking plate does not lock the rim correctly.	<ol style="list-style-type: none"> <li>1. The pneumatic system is not connected to the TCE 4225.</li> <li>2. Insufficient pressure in the pneumatic system.</li> <li>3. The pressure reducing valve is closed or incorrectly adjusted.</li> </ol>	<ol style="list-style-type: none"> <li>1. Connect the pneumatic system.</li> <li>2. Adjust pneumatic pressure to the correct value.</li> <li>3. Open or adjust correctly the pressure reducing valve.</li> </ol>
The bead breaker force is not enough for bead breaking.	<ol style="list-style-type: none"> <li>1. The pneumatic system is not connected to the TCE 4225.</li> <li>2. Insufficient pressure in the pneumatic system.</li> <li>3. The pressure reducing valve is closed or wrongly adjusted (valid for the versions that use this kind of device).</li> <li>4. The tire is not completely deflated.</li> </ol>	<ol style="list-style-type: none"> <li>1. Connect the pneumatic system.</li> <li>2. Adjust pneumatic pressure to the correct value.</li> <li>3. Open or adjust correctly the pressure reducing valve.</li> <li>4. Remove the valve element from the valve until complete deflation of the tire.</li> </ol>
The manometer does not indicate the correct pressure when operating the inflation pedal.	<ol style="list-style-type: none"> <li>1. The connecting pipes of the manometer are incorrectly connected.</li> </ol>	<ol style="list-style-type: none"> <li>1. Invert the connection of the connecting pipes of the manometer on the joints of the inflation pedal.</li> </ol>

## 6. Maintenance

### 6.1 Suggested lube

Component	Lube	Standard
Gearbox	ESSO Spartan EP460	ISO 460 DIN 51502-CLP ISO 34-98-CC
Pneumatic system (conditioning assembly)	ESSO FEBIS K 32	ISO VG 32

Tab. 1: Lubricants table.

**!** The manufacturer is not liable for any damage caused by use of lubes different from those shown in the table.

### 6.2 Cleaning and servicing



Before any cleaning or maintenance intervention, disconnect the TCE 4225 by means of the main switch and disconnect the network plug.



Before any cleaning or maintenance intervention, disconnect the pneumatic system of the TCE 4225.

To guarantee full efficiency of the TCE 4225 and to ensure functioning without anomalies it is essential to clean the machine regularly and carry out periodical maintenance.

Maintenance has to be carried out by the operator in accordance with the manufacturer's prescriptions shown here below.

### 6.2.1 Maintenance intervals

Maintenance	weekly	monthly	annual
Clean the mechanical moving parts, spray them with nebulized oil or cherosene and lube with appropriate grease	x		
Remove the condensate from the filter assembly.	x		
Check oil level in the oil nebulizer.		x	
Check transmission belt tensioning in order to avoid its sliding.		x	
Check the oil level in the gearbox and keep it always between minimum and maximum level.			x
Change oil in the oil nebulizer.			x

### 6.2.2 Condensate removal

1. Turn left the red button placed in the lower part of the water separator.
2. Remove the accumulated condensate by pressing the same button.
3. Turn back in previous position the red button placed in the lower part of the water separator.

### 6.2.3 Nebulizer oil refill

1. Disconnect pneumatic connection.
2. Unscrew the tank cap on the oil nebulizer.
3. Top up oil (see lube table).

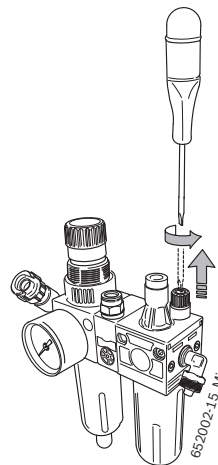

### 6.2.4 Change oil in the oil nebulizer

1. Disconnect pneumatic connection.
2. Unscrew the tank cap on the oil nebulizer.
3. Discharge oil and dispose it (see chap. 7.3).
4. Top up with new oil (see lube table).



## 6.3 Spare and wearing parts

Denomination	Order code
Mounting tool adhesive tag	1 695 100 982
Electrical tension adhesive tag	1 695 100 789
Bead breaker adhesive tag	1 695 100 983
Aisles protections for 20" plate	1 695 105 083
Bead breaker blade screw	1 695 103 347
Mounting tool	1 695 102 647
Tool tab protections (5 pieces)	1 695 101 608
Mounting tool cover	1 695 102 725
Bead breaker blade	1 695 100 897
Front bead breaker support	1 695 100 643
Rear bead breaker support	1 695 100 654

## 7. Decommissioning

### 7.1 Place change

Procedure:

1. Disconnect electrical connection.
2. Disconnect pneumatic connection.
3. Dismantle the column switch and lean it at the side.
4. Follow what shown for first start up (see chap. 4.2).
5. Fix again the TCE 4225 with its four screws on the pallet (see chap. 4.2).

 In case of sale or transfer of TCE 4225, all the documents included in the consignment volume has to be integrally handed over together with the equipment.

### 7.2 Temporary decommissioning

If the TCE 4225 is going to be stopped for a limited period of time or if the equipment is not being used for other reasons, always disconnect the network plug from its socket!

It is suggested to clean accurately the TCE 4225, also its tools and accessories, and carry out a protection treatment (e.g. spraying of a thin oil film).

### 7.3 Disposal

- Disconnect the TCE 4225 from the mains tension and take off the power supply cable.
- Oil are water pollution risk fluids and have to be disposed of in accordance with the rules in force.
- Disassemble the TCE 4225, order the materials according to the category it belongs to and dispose of them according to the rules in force.



**TCE 4225 complies to the rules of the European directive 2002/96/CE (directive on the disposal of electrical and electronic waste).**

Electric and electronic devices which are out of order, together with their cables, accessories, accumulators and batteries, have to be disposed of separately from household waste.

- For disposal of such products, use the available return and collection systems.
- The correct disposal of the TCE 4225 makes it possible to avoid environmental damage and to put at no risk the life of people.

## 8. Technical data

### 8.1 TCE 4225

Function	Specifications
Maximum noise level.	70 dB
Bead breaking cylinder force.	2600 N (2,6 t)
Compressed air supply	8 – 12 bar
Power supply tension	depending on the chosen tension (see identification plate)

### 8.2 Dimensions and weights

Function	Specifications
TCE 4225 (H x W x D)	1740 x 1000 x 1300 mm
Net weight	213 kg
Gross weight	252 kg

### 8.3 Reach

#### 8.3.1 Car wheels

Function	min / max
Tire width	3" – 10"
Maximum tire diameter	1000 mm
Rim diameter (internal locking)	13" – 23"
Rim diameter (external locking)	10" – 20"

#### 8.3.2 Motorcycle wheels

Function	min / max
Tire width	3" – 7"
Maximum tire diameter	1000 mm
Rim diameter	14" – 23"

 To operate on motorbike wheels it is necessary to install the motorbike wheel fitting device, available upon request (see chap. 3.4).

## 9. Glossary

### Rim, structure and names

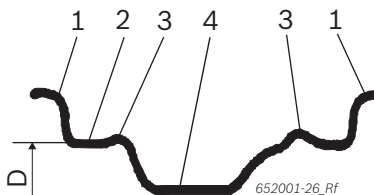

Fig. 3: Rim

- 1 Rim edge
- 2 Rim shoulder
- 3 Hump (lifted edge)
- 4 Semi drop centre
- D Rim diameter

### RFT

Run Flat Tyre, tire with emergency functioning features, normal wheel and spare wheel at the same time.

### TCE

Tyre Change Equipment, abbreviation for tire changer.

### UHP

UltraHighPerformance tires, name of the brand of a tire for high speeds.

### wdk

German rubber industry association (registered association).