



WBE 5210



BOSCH

de Ersatzteilliste
Auswuchtmaschine

en Spare parts list
Wheel Balancer machine

Diese Ersatzteilliste enthält zusätzlich zu den festgelegten Ersatzteilen auch Informationen, die für die Montage und Demontage des Erzeugnisses, der dazugehörigen Baugruppen, des Zubehöres und des Sonderzubehöres erforderlich sind.	In addition to the defined service parts this list of service parts also contains information, which is required for assembling and disassembling the product, related modules, accessories and optional equipment.
Als Ersatzteil festgelegt sind all die Teile, die in der Spalte Info mit „x“ gekennzeichnet sind. Nur für diese festgelegten Ersatzteile können Preis und Lieferzeit direkt abgefragt werden. In der Preisliste sind nur diese festgelegten Ersatzteile aufgeführt.	Defined as a service part are all parts which are marked by „x“ in column „Info“. Prices and delivery times can only be directly queried for these specified parts. The price list only contains these specified service parts.
Bestellung, Preis- und Lieferzeitanfragen von nicht geplanten Ersatzteilen sind schriftlich an AA-DG/LOG zu richten. Mit längeren Lieferzeiten ist hier zu rechnen	All queries regarding orders, prices and delivery times of non-scheduled service parts are to be addressed in writing to AA-DG/LOG. Longer delivery times should be expected here.
Zeichenerklärung:	Code identification:
* Produktvariante	* Product variant
** Modellpflege	** Modell upgrading
 Zusatzinformation in „Änderungen“	 Further information see „modifications“
→ bis Fertigungsdatum	→ Manufactured before
↳ ab Fertigungsdatum	↳ Manufactured after

WBE 5210

Bezeichnung Designation Dénomination Designación	Bestellnummer Part number Référence Núm. de pedido	Fertigung seit Production ban fabrication de fabricación de	Fertigungsverbot seit Production ban Interdiction de fabrication Prohibición de fabricación	Ersatzteilpflicht bis Service part obligation Obligation de pièce de rechange Obligación de disp. de piezas de recambio	Bemerkungen Notes Notes Notas
WBE 5210	1 694 100 050	01/2008			230V, 1~, 50Hz, green (RAL6018)
WBE 5210	1 694 100 051	01/2008			230V, 1~, 60Hz, green (RAL6018)
WBE 5210	1 694 100 052	01/2008			110V, 1~, 50Hz, green (RAL6018)
WBE 5210	1 694 100 053	01/2008			110V, 1~, 60Hz, green (RAL6018)
WBE 5210 S50	1 694 100 157				230V, 1~, 50Hz, grey (RAL7016)

Pos.	Info	Partnumber	BEZEICHNUNG (de) Kommentar (de)	IDENTIFICATION (en) Comment (en)	Drawing
1	x	1695654653	Abdeckung	Cover	
2	x	1695654679	Bedien-/Anzeigeeinheit	Control/Display Unit	
3	x	1695653756	Hauptplatine	Motherboard	
6	x	1695611100	Lichtschanke	Photoelec. Light Barrier	
8	x	1695627500	Halterung	Holder	
9	x	1695654654	Bedien-/Anzeigeeinheit	Control/Display Unit	
13	x	1695040974	Kabeldurchführung	Cable Passage	
20	x	1695101413	Druckluftfilter	Compressed-Air Filter	
22	x	1695654393			
24	x	1695040975	Mikroschalter	Microswitch	
25	x	1695653815	Mikroschalter	Microswitch	
28	x	1695042433	Mikroschalter	Microswitch	
29	x	1695653948	Schutz	Protection	
30	x	1695653957	Ventil	Valve	

Pos.	Info	Partnumber	BEZEICHNUNG (de) Kommentar (de)	IDENTIFICATION (en) Comment (en)	Drawing
1	x	1695041409	Schalter	Switch	
2	x	1695042225	Gerätesteckdose	Equipment Socket	
9	x	1695654415	Netzanschlussleitung	Power supply cord	
10	x	1695653703	Kabelsatz	Cable Set	
12	x	1695654549	Leiterplatte	Printed Circuit Board	
13	x	1695645500			
14	x	1695041378	Feinsicherung	Fine Fuse	
15	x	1695654409	Elektr Leitung	Cable	
16	x	1695653815	Mikroschalter	Microswitch	
17	x	1695654463	Elektr Leitung	Cable	
19	x	1695040037	Scheibe	Washer	
20	x	1695636100	Antriebsflansch	Drive Flange	
22	x	1695041363	Motorkondensator	Motor Capacitor	
23	x	1695041362	Motorkondensator	Motor Capacitor	
24	x	1695042806	Motor	Motor	

Pos.	Info	Partnumber	BEZEICHNUNG (de) Kommentar (de)	IDENTIFICATION (en) Comment (en)	Drawing
1	x	1695041409	Schalter	Switch	
2	x	1695042225	Gerätesteckdose	Equipment Socket	
9	x	1695654415	Netzanschlussleitung	Power supply cord	
10	x	1695653660	Kabelsatz	Cable Set	
11	x	1695653703	Kabelsatz	Cable Set	
12	x	1695654549	Leiterplatte	Printed Circuit Board	
13	x	1695645500			
14	x	1695041377	Feinsicherung	Fine Fuse	
15	x	1695654409	Elektr Leitung	Cable	
16	x	1695653815	Mikroschalter	Microswitch	
17	x	1695654463	Elektr Leitung	Cable	
19	x	1695040037	Scheibe	Washer	
20	x	1695636100	Antriebsflansch	Drive Flange	
22	x	1695041360	Kondensator	Condenser	
23	x	1695041361	Kondensator	Condenser	
24	x	1695042805	Motor	Motor	

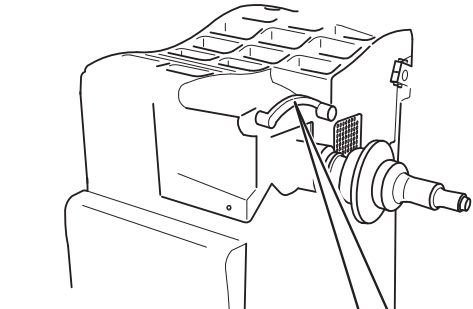
Pos.	Info	Partnumber	BEZEICHNUNG (de) Kommentar (de)	IDENTIFICATION (en) Comment (en)	Drawing
2	x	1695653514	Hebel	Lever	
3	x	1695653507	Buchse	Bushing	
4	x	1695613400	Feder	Spring	
6	x	1695653494	Achse	Axle	
7	x	1695653508	Buchse	Bushing	
10	x	1695653510	Kunststoffformteil	Plastic Moulding	
11	x	1695653511	Kunststoffformteil	Plastic Moulding	
12	x	1695653502	Deckel	Cover	

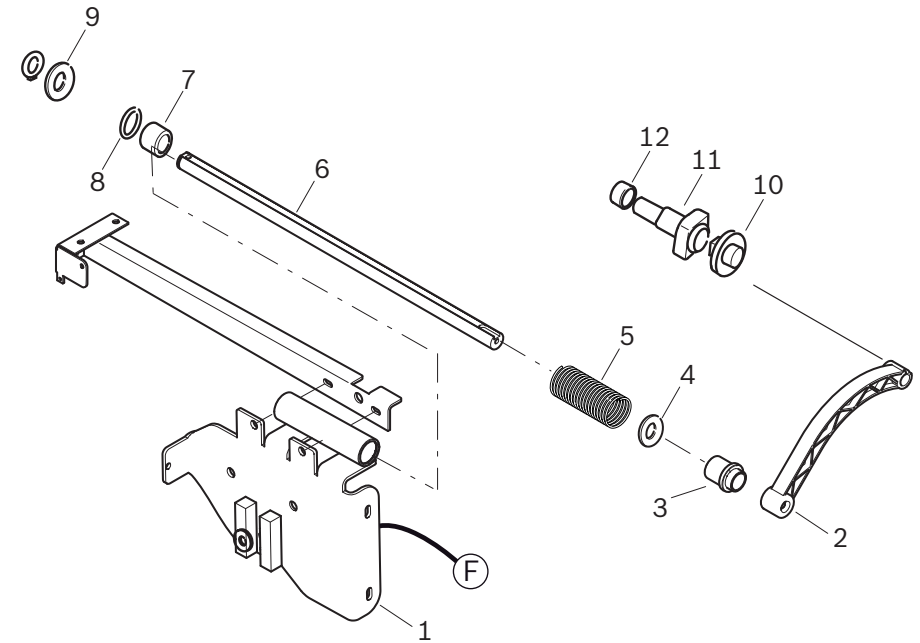

Pos.	Info	Partnumber	BEZEICHNUNG (de) Kommentar (de)	IDENTIFICATION (en) Comment (en)	Drawing
1	x	1695654434	Lichtschranke	Photoelec. Light Barrier	
2	x	1695040834			
3	x	1695002104	Scheibe	Washer	
6	x	1695654777	Wegaufnehmer	Displacement sensor	
11	x	1695041335	Riemen	Belt	
12	x	1695603700	Ring	Ring	
13	x	1695603600	Lochscheibe	Perforated disk	
14	x	1695653202	Riemenscheibe	Pulley	
15	x	1695041439	Lager	Bearing	
23	x	1695654776	Wegaufnehmer	Displacement sensor	
25	x	1695040422	Ring	Ring	
26	x	1695040423	Scheibe	Washer	
27	x	1695040424	Ring	Ring	
28	x	1695040426	Kugellager	Ball Bearing	
31	x	1695654290	Haltekörper	Supporting Device	
801	x	1695654752	Wegaufnehmer	Displacement sensor	

Pos.	Info	Partnumber	BEZEICHNUNG (de) Kommentar (de)	IDENTIFICATION (en) Comment (en)	Drawing
4	x	1695652846	Halter	Support	
7	x	1695653220	Rolle	Roller	
13	x	1695040177			
14	x	1695100093	Zapfen	Pivot	
16	x	1695104524	Ersatzteilsatz	Service kit	
23	x	1695001363	Scheibe	Washer	
25	x	1695001363	Scheibe	Washer	
30	x	1695001363	Scheibe	Washer	
31	x	1695653219	Rolle	Roller	
32	x	1695001363	Scheibe	Washer	
36	x	1695001363	Scheibe	Washer	
38	x	1695653219	Rolle	Roller	
42	x	1695002003	Mutter	Nut	
45	x	1695652848	Zapfen	Pivot	

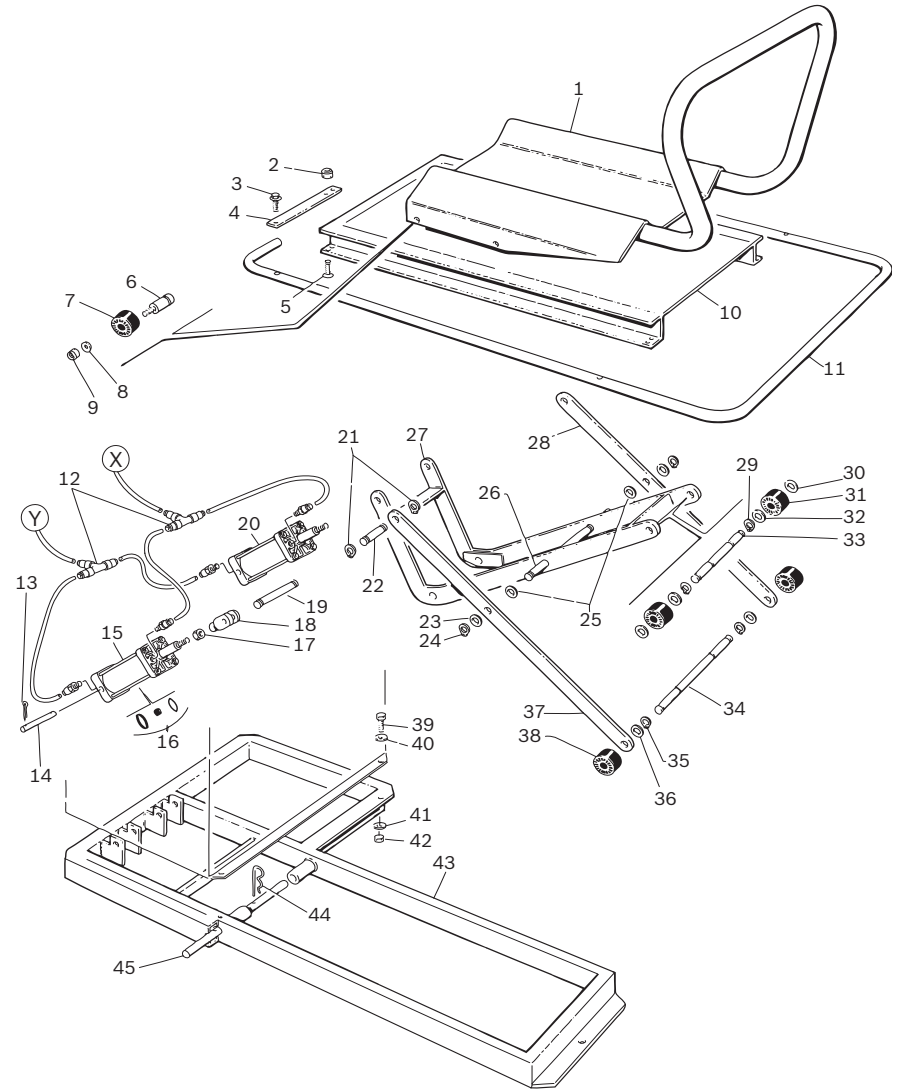

Pos.	Info	Partnumber	BEZEICHNUNG (de) Kommentar (de)	IDENTIFICATION (en) Comment (en)	Drawing
1	x	1695605600	Konus	Cone	
	x		75 - 110		
2	x	1695652862	Konus	Cone	
	x		54 - 80		
3	x	1695632500	Zentrierkonus	centering cone	
	x		42 - 65		
4	x	1695616500	Manschette	Sleeve	
5	x	1695616100	Ring	Ring	
6	x	1695654361	Griff	Handle	
7	x	1695652951			
8	x	1695616200	Schnellspanvorrichtung	Quick-Clamping Device	
9	x	1695635000	Innensechskantschluessel	Hexagon Socket Screw Key	
10	x	1695602400	Schnellspanmutter	Fast Locking Flange	
801	x	1695629400	Lehre	Gauge	
802	x	1695652870	Messschieber	Caliper	
803	x	1695606500	Zange	Pair Of Tongs	
804	x	1695606200	Distanzring	Spacer Ring	
805	x	1695606300	Zentrierkonus	centering cone	
	x		120 - 174		
806	x	1695653449	Zentrierkonus	centering cone	
	x		89 - 132		

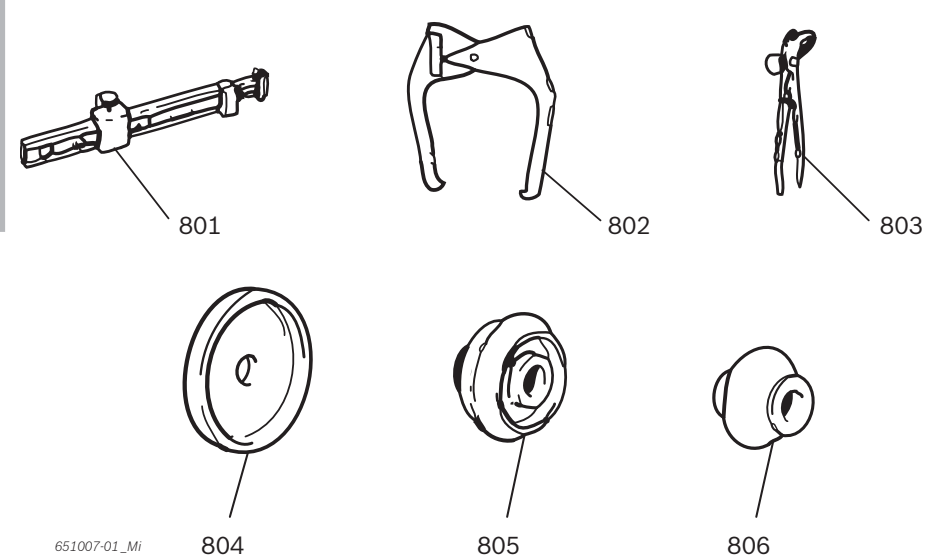

Pos.	Info	Partnumber	BEZEICHNUNG (de) Kommentar (de)	IDENTIFICATION (en) Comment (en)	Drawing
1	x	1695627100			
2	x	1695635000	Innensechskantschlüssel	Hexagon Socket Screw Key	
4	x	1695652903	Zapfen	Pivot	
5	x	1695626800			
6	x	1695652901			
7	x	1695652902			
8	x	1695652861	Aufnahme	Holding Fixture	
10	x	1695616100	Ring	Ring	
11	x	1695616500	Manschette	Sleeve	
12	x	1695632500	Zentrierkonus	centering cone	
13	x	1695652862	Konus	Cone	
14	x	1695605600	Konus	Cone	
16	x	1695606300	Zentrierkonus	centering cone	

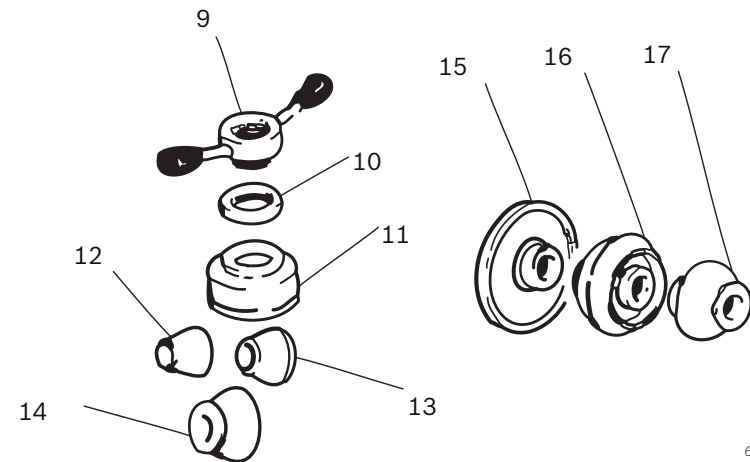
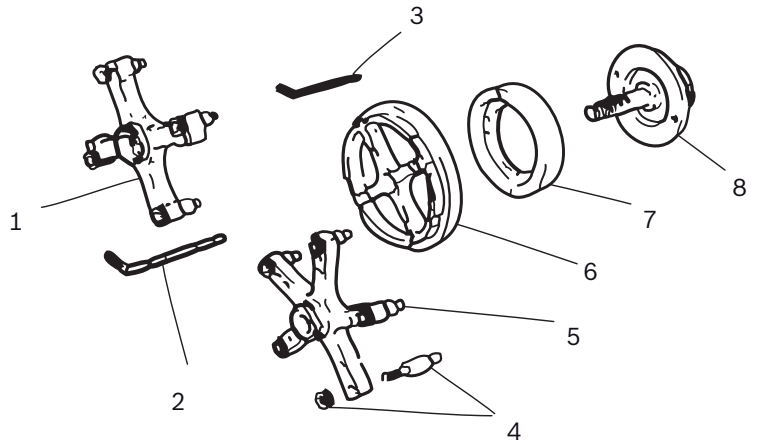

651016-13_Rf

Pos.	Info	Partnumber	BEZEICHNUNG (de) Kommentar (de)	IDENTIFICATION (en) Comment (en)	Drawing
9	x	1695604800	Konus	Cone	
11	x	1695654117	Schnellspanvorrichtung	Quick-Clamping Device	
12	x	1695605100	Nutmutter	Slotted Round Nut	
15	x	1695604200	Kegeldorn	Taper mandrel	

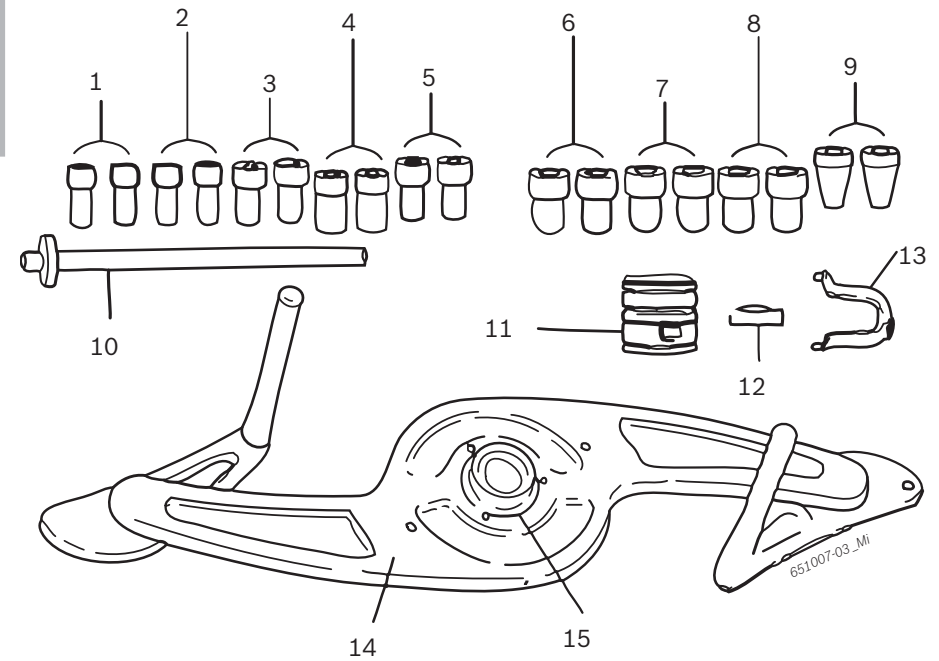

Pos.	Info	Partnumber	BEZEICHNUNG (de) Kommentar (de)	IDENTIFICATION (en) Comment (en)	Drawing
4	x	1695654122	Pratze	Claw	
5	x	1695607500	Mutter	Nut	
7	x	1695654118	Zentrierring	Locating Ring	
8	x	1695654120	Zentrierring	Locating Ring	
9	x	1695654119	Zentrierring	Locating Ring	
18	x	1695629100	Messschieber	Caliper	
801	x	1695612100	Schnellspannkonus	fast-action cone	

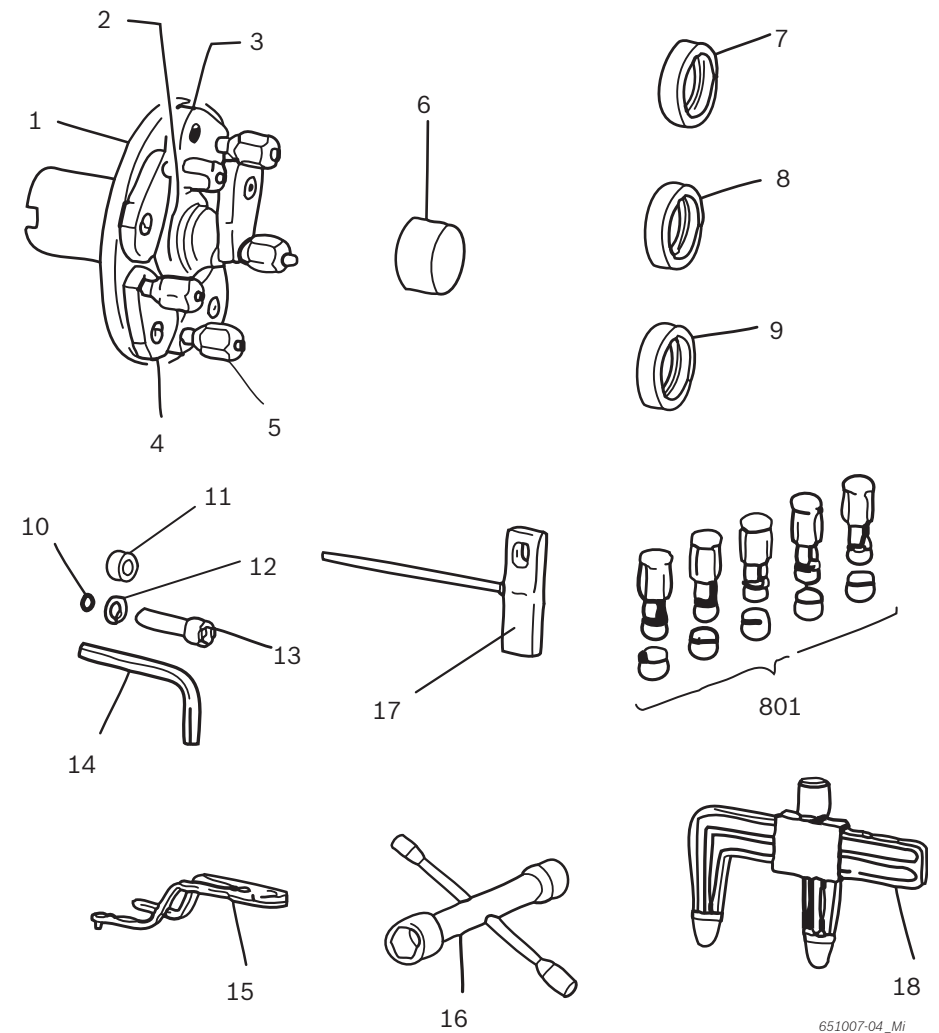

651007-04_Mi

Datum	Bearbeiter	Änderung
2010-09-30	Mi	Spare parts updated and reduced to available spare parts
2010-01-15	Mi	Spare parts updated
2009-12-11	Mi	KP1 data updated
2009-11-16	Mi	Spare parts updated
2009-06-29	Mi	Spare parts updated
2009-01-02	Rf	Accessories trucks and Spare parts updated
2008-11-10	Rf	Accessories trucks and Spare parts updated
2008-09-28	Rf	Spare parts updated
2008-07-12	Rf	Numbers updated
2008-07-07	Rf	Spare parts uodated
2008-07-04	Rf	New created

Robert Bosch GmbH

Diagnostics

Franz-Oechsle-Straße 4

73207 Plochingen

DEUTSCHLAND

www.bosch.com

bosch.prueftechnik@bosch.com

1 695 654 767 | 2010-01-15