

WBE 4430



BOSCH

de Ersatzteilliste
en Spare part list

fr Liste de recambio
es Lista de

Class	----- de -----	----- en -----	----- fr -----	----- es -----	----- it -----
●	Verschleißteil: Definition: Zu erwartende Lebensdauer des Teiles ist kleiner als die zu erwartende Lebensdauer des Produktes! - Bei Ausfall nicht mehr funktionsfähig oder sicherer Einsatz des Produktes nicht mehr gewährleistet - Verminderte Gewährleistung - Wir empfehlen, diese Ersatzteile im lokalem Lager zu bevorraten. Hinweis: Der Verschleiß und das Wartungsintervall sind abhängig von: - der Einsatzzeit (O2-Sensor) - Art und Häufigkeit der Verwendung (OBD-Verbindungsleitung) - Alter der Maschine (Filter..)	Wearing part: Definition: The expected lifetime of the part is shorter than the expected lifetime of the product! - In the event of failure, no longer functional or safe use of product no longer guaranteed - Reduced warranty - We recommend stocking these replacement parts in the local warehouse. Note: Wear and the maintenance interval depend on: - Usage time (O2 sensor) - Nature and frequency of use (OBD connecting cable) - Age of machine (filter..)	Pièce d'usure : Définition : La durée de vie prévisible de la pièce est inférieure à la durée de vie prévisible du produit ! - Plus en ordre de marche en cas de panne ou utilisation sûre du produit plus garantie - Garantie réduite - Nous conseillons d'avoir ces pièces de rechange en réserve dans un entrepôt local. Remarque : L'usure et l'intervalle d'entretien dépendent des facteurs suivants : - durée d'utilisation (capteur d'O2) - nature et fréquence de l'utilisation (câble de liaison OBD) - âge de la machine (filtre..)	Pieza de desgaste: Definición: La vida útil esperada de la pieza es menor que la vida útil esperada del producto. - En caso de avería ya no está en condiciones de funcionar o el uso seguro del producto ya no se garantiza - Garantía reducida - Se recomienda almacenar esas piezas de recambio en un almacén local. Nota: El desgaste y el intervalo de mantenimiento dependen: - del tiempo de servicio (sensor O2) - del tipo y frecuencia de uso (cable de conexión OBD) - de la edad de la máquina (filtro...)	Parte soggetta a usura: Definizione: Il ciclo di vita prevedibile del componente è inferiore al ciclo di vita prevedibile del prodotto. - In caso di avaria il prodotto non è più in grado di funzionare oppure non ne è più garantita la sicurezza d'impiego - Garanzia ridotta - Consigliamo di tenere una scorta di questi ricambi nel magazzino ocale. Avvertenza: l'usura e l'intervallo di manutenzione dipendono da: - tempo operativo (sensore O2) - tipo e frequenza dell'impiego (cavo di collegamento OBD) - età della macchina (filtro...)
ⓘ		Function part: Definition: The expected lifetime of the part is the same as or longer than the expected lifetime of the product! - In the event of failure, no longer functional or safe use of product no longer guaranteed - Standard warranty - We recommend stocking these replacement parts in the local warehouse.	Pièce fonctionnelle : Définition : La durée de vie prévisible de la pièce est égale ou supérieure à la durée de vie prévisible du produit ! - Plus en ordre de marche en cas de panne ou utilisation sûre du produit plus garantie - Garantie standard - Nous conseillons d'avoir ces pièces de rechange en réserve dans un entrepôt local.	Pieza funcional: Definición: La vida útil esperada de la pieza es igual o mayor que la vida útil esperada del producto. - En caso de avería ya no está en ndiciones de funcionar o el uso seguro del producto ya no se garantiza - Garantía estándar - Se recomienda almacenar esas piezas de recambio en un almacén local.	Parte funzionale: Definizione: Il ciclo di vita prevedibile del componente è uguale o superiore al ciclo di vita prevedibile del prodotto. - In caso di avaria il prodotto non è più in grado di funzionare oppure non ne è più garantita la sicurezza d'impiego - Garanzia standard - Consigliamo di tenere una scorta di questi ricambi nel magazzino locale.
○	Nicht-Funktionsteil: Definition: Die zu erwartende Lebensdauer des Teiles ist gleich oder größer als die zu erwartende Lebensdauer des Produktes! - Bei Ausfall weiterhin funktionsfähig und ein sicherer Einsatz des Produktes ist gewährleistet - Standard Gewährleistung - Wir empfehlen, diese Ersatzteile bei einem Bedarf über das Zentrallager zu bestellen.	Non-function part: Definition: The expected lifetime of the part is the same as or longer than the expected lifetime of the product! - In the event of failure, still functional and safe use of the product is guaranteed - Standard warranty - We recommend ordering these replacement parts as required via the central warehouse.	Pièce non fonctionnelle : Définition : La durée de vie prévisible de la pièce est égale ou supérieure à la durée de vie prévisible du produit ! - Toujours en ordre de marche en cas de panne et utilisation sûre du produit garantie - Garantie standard - Nous recommandons de commander ces pièces de rechange au besoin par le biais de l'entrepôt central.	Pieza no funcional: Definición: La vida útil esperada de la pieza es igual o mayor que la vida útil esperada del producto. - En caso de avería aún en condiciones de funcionar y el uso seguro del producto se garantiza - Garantía estándar - Se recomienda pedir esas piezas de recambio al almacén central, en caso de necesidad.	Parte non funzionale: Definizione: Il ciclo di vita prevedibile del componente è uguale o superiore al ciclo di vita prevedibile del prodotto. - In caso di avaria il prodotto continua ad essere in grado di funzionare e ne rimane garantita la sicurezza d'impiego - Garanzia standard - Consigliamo di ordinare questi ricambi in caso di necessità attraverso il magazzino centrale.

Intervall	Wartungsintervall des Verschleißteiles	Maintenance intervall for wearing part	Intervalle d'entretien de la pièce d'usure	Intervalo de mantenimiento de la pieza de desgaste	Intervallo di manutenzione della parte soggetta a usura
h	Stunden	hours	heures	Horas	ore
d	1 695 656 430 - 2011-07-12	days	jours	Días	giorni
m	Monate	month	mois	Meses	mesi
cy	Zyklen	cycles	cycles	Ciclos	cicli
-	ohne definiertes Wartungsintervall	No defined maintenance interval	pas d'intervalle d'entretien défini	Sin intervalo de mantenimiento definido	senza intervallo di manutenzione definito

Customer	Austausch des Teiles durch den Kunden (Werkstatt)	Replacement of part by customer (workshop)	Remplacement de la pièce par le client (atelier)	Sustitución de la pieza por el cliente (taller)	La sostituzione del componente da parte del cliente (officina)
-	ist nicht erlaubt.	Not permissible.	pas autorisé	no está permitida.	non è ammessa.
x	ist erlaubt (Diese Ersatzteile sind auch in der Betriebsanleitung aufgeführt)	Permissible (these replacement parts are also listed in the operating instructions)	autorisé (ces pièces de rechange sont également indiquées dans la notice)	está permitida (estas piezas de recambio también se indican en las instrucciones de	è ammessa (questi ricambi sono riportati anche nelle istruzioni d'uso)

Part-number	ACS 600 / ACS 601	Order number of replacement part or reference to standard part	Référence de commande de la pièce de rechange ou signalement de pièce normalisée	Número de pedido de la pieza de recambio o nota sobre la pieza normalizada	Codice di ordinazione del ricambio o avvertenza sul componente unificato
Normpart	Normteil: Ersatzteile, die normalerweise über unterschiedliche Kanäle bezogen werden können wie z. B. Schrauben, Muttern, O-Ringe, Tintenpatronen. Alle 3 Ersatzteil-Kategorien (siehe Class) sind möglich	Normpart (Standard part): Replacement parts which can normally be obtained through various channels e.g. bolts, nuts, O-rings, ink cartridges. All 3 replacement part categories (refer to Class) are possible	Pièce normalisée : Pièces de rechange qui peuvent normalement être obtenues par le biais de différents canaux, par ex. les vis, écrous, joints toriques, cartouches d'encre. Les 3 catégories de pièces de rechange (voir Class) sont possibles	Pieza normalizada: Piezas de recambio que se pueden adquirir normalmente a través de diferentes vías, p. ej., tornillos, tuercas, anillos de sección circular, cartuchos de tinta. Las tres categorías de piezas de recambio (véase clase) son posibles.	Parte unificata (componente unificato): Si tratta di ricambi che in genere possono essere acquistati attraverso diversi canali, come ad es. viti, dadi, O-ring, cartucce di inchiostro. Sono possibili tutte e 3 le categorie di ricambi (vedi Class)

Bezeichnung Designation Dénomination Designación	Bestellnummer Partnumber Référence Núm.depedido	Gefertigt von Production since fabrication de fabricación de	Gefertigt bis produced until fabrication fabricación	Ersatzteilpflicht bis Service part obligation Obligation de pièce de rechange Obligación de disp. de piezas de recambio	Bemerkungen Notes Notes Notas
WBE 4430	1 694 100230	lug-11			110 V, 1~, 60 Hz, green (RAL 6018)
WBE 4430 S10	1 694 100232	lug-11			230 V, 1~, 50/60 Hz, green (RAL 6018)
WBE 4430 S10	1 694 100233	lug-11			110 V, 1~, 60 Hz, green (RAL 6018)
WBE 4430 S50	1 694 100236	lug-11			110 V, 1~, 60 Hz, grey (RAL 7016)
WBE 4430 S50	1 694 100237	lug-11			230 V, 1~, 50 Hz, grey (RAL 7016)
WBE 4430 S46	1 694 100243	lug-11			230 V, 1~, 50 Hz, grey (RAL 9006)
WBE 4430 S30	1 694 100246	lug-11			230 V, 1~, 60 Hz, grey (RAL 7016)

Pos.	Class	Intervall	Customer	Partnumber	BEZEICHNUNG (de)	IDENTIFICACION (es)
					IDENTIFICATION (en)	IDENTIFICATION (fr)
					Kommentar (de)	Comment (en)
1	●	-	-	1695656511	Pedalwerk Pedal Unit	Pedaleria Groupe Pedale
2	○	-	-	1695040834	Schraube Screw (No. 4 pz)	Vite Vis
3	●	-	-	1695654994	Laserpointer Laser pointer	Puntatore laser Pointeur laser
3*	○	-	-	1695655479	Teilesatz Parts Set	Serie Parti Jeu De Pieces
4	○	-	-	1695655266	Leiterplatte Printed Circuit Board	Circuito Stampato Circuit Imprime
5	○	-	-	1695655945	Kunststoffabdeckung plastic covering	
6	●	-	-	1695042737	Monitor Monitor	Monitor Moniteur
7	○	-	-	1695655342	Teilesatz Parts Set	Serie Parti Jeu De Pieces
801	○	-	-	1695655375	Befestigungsbausatz Mounting Kit	Gruppo Di Fissaggio Pieces De Fixation
802	○	-	-	1695656450	Befestigungsbausatz Mounting Kit	Gruppo Di Fissaggio Pieces De Fixation

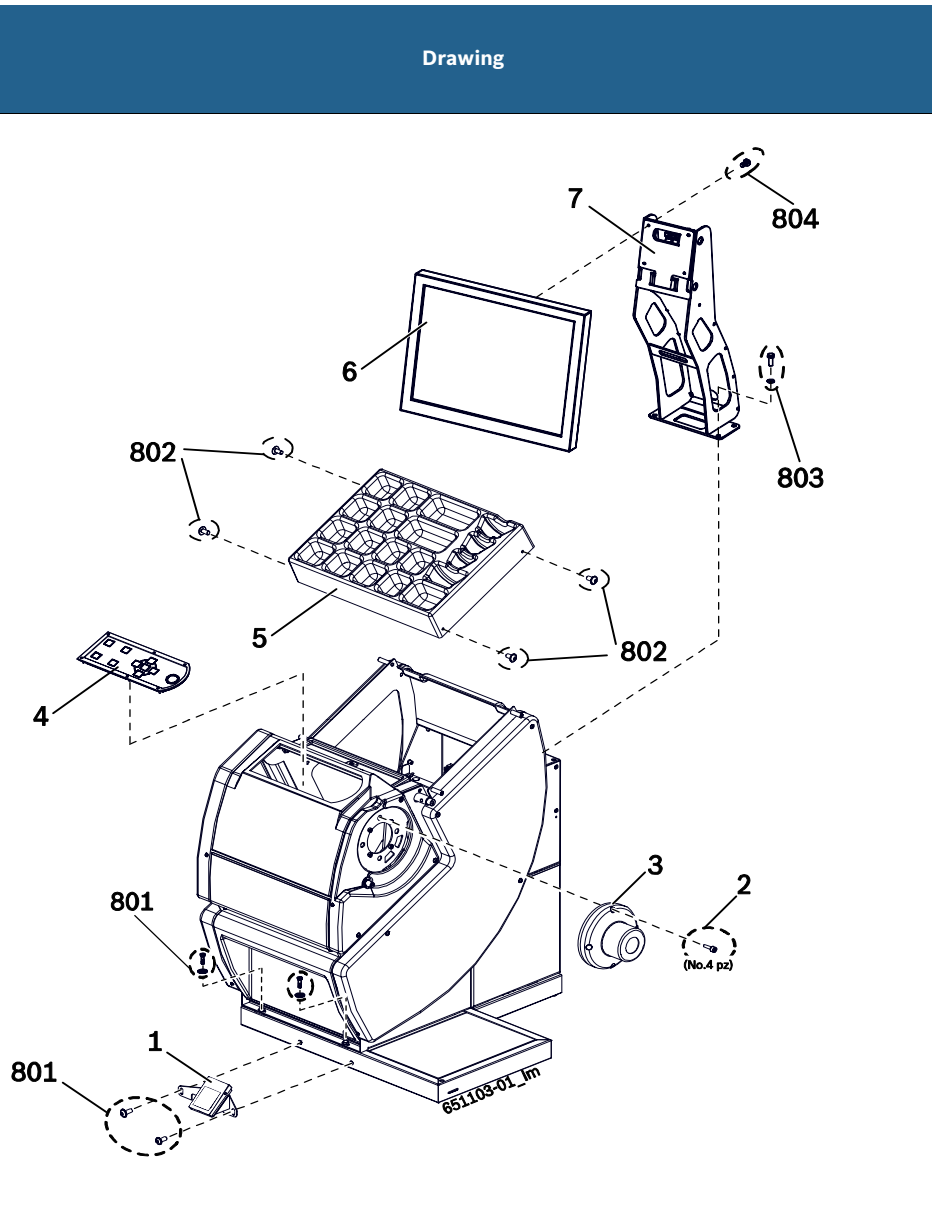

Pos.	Class	Intervall	Customer	Partnumber	BEZEICHNUNG (de)	IDENTIFICACION (es)	Drawing
					IDENTIFICATION (en)	IDENTIFICATION (fr)	
					Kommentar (de)	Comment (en)	
803	○	-	-	1695655382	Befestigungsbausatz Mounting Kit	Gruppo Di Fissaggio Pieces De Fixation	
804	○	-	-	1695655405	Befestigungsbausatz Mounting Kit	Gruppo Di Fissaggio Pieces De Fixation	

Pos.	Class	Intervall	Customer	Partnumber	BEZEICHNUNG (de)	IDENTIFICACION (es)	Drawing
					IDENTIFICATION (en)	IDENTIFICATION (fr)	
					Kommentar (de)	Comment (en)	

Pos.	Class	Intervall	Customer	Partnumber	BEZEICHNUNG (de)	IDENTIFICACION (es)	Drawing
					IDENTIFICATION (en)	IDENTIFICATION (fr)	
					Kommentar (de)	Comment (en)	
1	○	-	-	1695655100	Kunststoffabdeckung		
					plastic covering		
					RAL. 7016		
2	○	-	-	1695655105	Abdeckung	Copertura	
					Cover	Recouvrement	
					RAL. 7016		
3	○	-	-	1695655103	Kunststoffabdeckung		
					plastic covering		
					RAL. 7016		
4	○	-	-	1695655120	Abdeckung	Copertura	
					Cover	Recouvrement	
					RAL. 7016		
5	○	-	-	1695655122	Abdeckung	Copertura	
					Cover	Recouvrement	
					RAL. 6018		
5*	○	-	-	1695655513	Abdeckung	Copertura	
					Cover	Recouvrement	
					RAL.7016		
5**	○	-	-	1695655708	Abdeckung	Copertura	
					Cover	Recouvrement	
					RAL.9006		
6	○	-	-	1695655388	Abdeckung	Copertura	
					Cover	Recouvrement	
					RAL.6018		
6*	○	-	-	1695655532	Kunststoffabdeckung		
					plastic covering		
					RAL.7016		
6**	○	-	-	1695655705	Kunststoffabdeckung		
					plastic covering		
					RAL.9006		

Pos.	Class	Intervall	Customer	Partnumber	BEZEICHNUNG (de)	IDENTIFICACION (es)
					IDENTIFICATION (en)	IDENTIFICATION (fr)
					Kommentar (de)	Comment (en)
7	○	-	-	1695655138	Traverse	Traversa
					Girder	Traverse
					RAL.7016	
8	○	-	-	1695655947	Kunststoffabdeckung	
					plastic covering	
9	○	-	-	1695656336	Kunststoffabdeckung	
					plastic covering	
					RAL.6018	
9*	○	-	-	1695656384	Kunststoffabdeckung	
					plastic covering	
9**	○	-	-	1695656389	Kunststoffabdeckung	
					plastic covering	
					RAL.9006	
801	○	-	-	1695655387	Befestigungsbausatz	Gruppo Di Fissaggio
					Mounting Kit	Pieces De Fixation

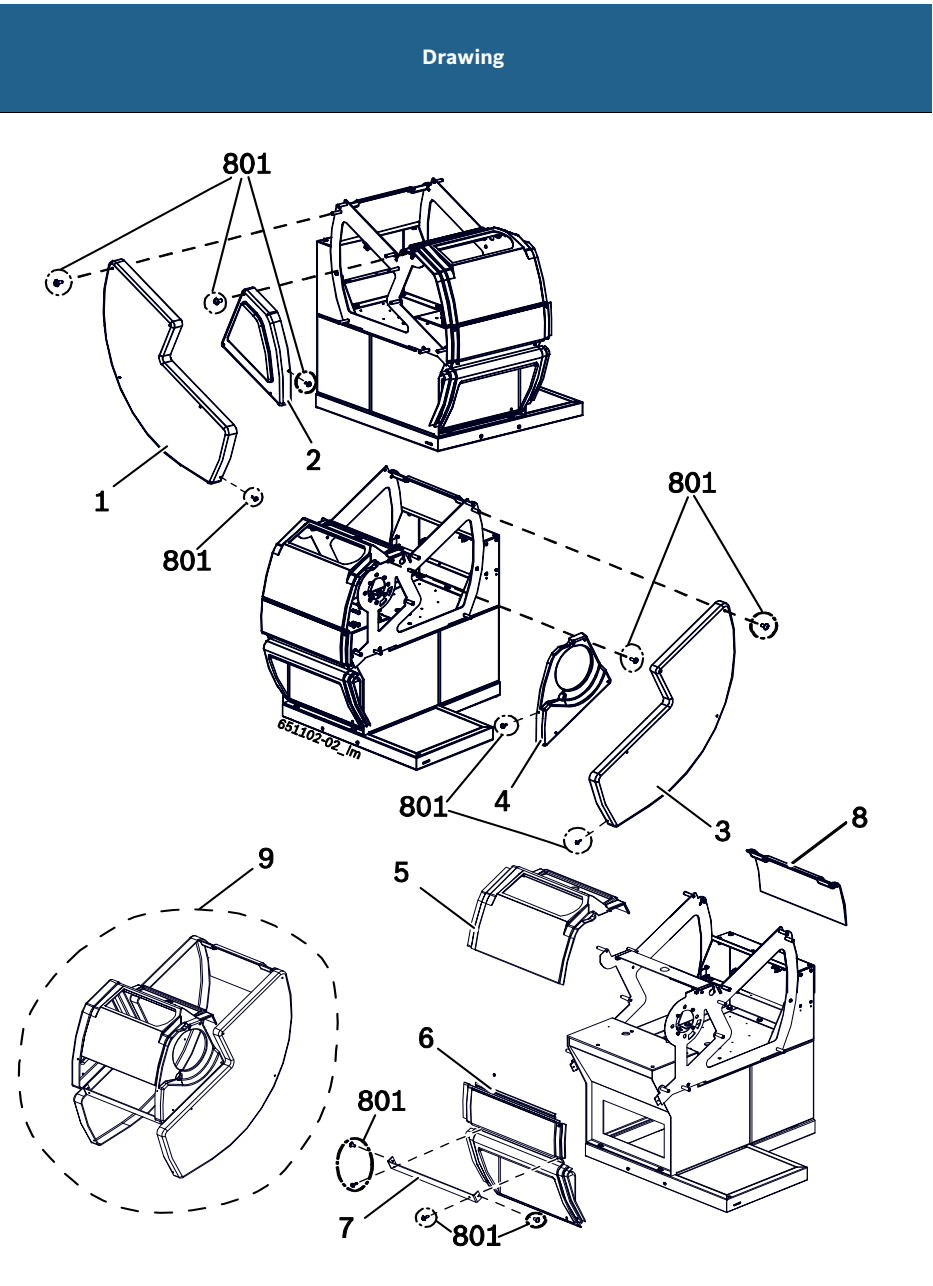

Pos.	Class	Intervall	Customer	Partnumber	BEZEICHNUNG (de)	IDENTIFICACION (es)	Drawing
					IDENTIFICATION (en)	IDENTIFICATION (fr)	
					Kommentar (de)	Comment (en)	
1	●	-	-	1695655962	Messsystem	Sistema di misura	
					Measuring system	Système de mesure	
2	●	-	-	1695654776	Wegaufnehmer	Rilevatore Di Percorrenza	
					Displacement sensor	Capteur De Deplacement	
3	●	-	-	1695654777	Wegaufnehmer	Rilevatore Di Percorrenza	
					Displacement sensor	Capteur De Deplacement	
4	●	-	-	1695655872	Elektromotor	Elettromotore	
					Motor (110V/1ph/ 60Hz)	Moteur	
4*	●	-	-	1695655965	Motorbaugruppe		
					Motor subassembly (230V/1ph/ 50-60Hz)		
5	●	-	-	1696504322	Wechselstrommotor	Motore A Corr.Altern.	
					Alternating-Current Motor (110V/1ph/ 60Hz)	Moteur Courant Alternatif	
5*	●	-	-	1695043282	Wechselstrommotor	Motore A Corr.Altern.	
					Alternating-Current Motor (230V/1ph/ 50-60Hz)	Moteur Courant Alternatif	
6	●	-	-	1695655963	Riemenscheibe	Puleggia	
					Pulley	Poulie	
7	○	-	-	169540431	Unterlegscheibe	Rondella piana	
					Plain Washer (No.4 pz)	Rondelle plate	

Pos.	Class	Intervall	Customer	Partnumber	BEZEICHNUNG (de)	IDENTIFICACION (es)	Drawing
					IDENTIFICATION (en)	IDENTIFICATION (fr)	
					Kommentar (de)	Comment (en)	
8	○	-	-	169543037	Innensechskantschraube	Vite cilindrica esagonal	
					Hex Socket Head Cap Screw (No.4 pz)	Vis cyl SixPans Creux CHC	
9	●	-	-	1695603600	Lochscheibe	Disco forato	
					Perforated disk	Disque Perfore	
10	○	-	-	1695603700	Ring	Anello	
					Ring	Bague	
11	○	-	-	1695653201	Gewinding	Anello Filettato	
					Threaded Ring	Bague Filetee	
12	●	-	-	1695654434	Lichtschranke	Barra Fotoelettrica	
					Photoelec. Light Barrier	Barriere Photoelectrique	
13	●	-	-	1695042409	Antriebsriemen	Cinghia Di Trasmissione	
					Drive Belt	Courroie D'entrainement	
14	○	-	-	169540427	Innensechskantschraube	Vite cilindrica esagonal	
					Hex Socket Head Cap Screw	Vis cyl SixPans Creux CHC	
15	●	-	-	1695656284	Messsystem	Sistema di misura	
					Measuring system (110V/1ph/ 60Hz)	Système de mesure	
15	●	-	-	1695655958	Messsystem	Sistema di misura	
					Measuring system (230V/1ph/ 50-60Hz)	Système de mesure	

Pos.	Class	Intervall	Customer	Partnumber	BEZEICHNUNG (de)	IDENTIFICACION (es)	Drawing
					IDENTIFICATION (en)	IDENTIFICATION (fr)	
					Kommentar (de)	Comment (en)	
1	○	-	-	169540418	Innensechskantschraube	Vite cilindrica esagonal	
					Hex Socket Head Cap Screw	Vis cyl SixPans Creux CHC	
					UNI 5931 M5X45 PF BRT		
2	●	-	-	1695653503	Kunststoffformteil	Pezzo Stampato D Plastica	
					Plastic Moulding	Piece Moulee En Plastique	
3	●	-	-	1695653504	Auswerfer	Espulsore	
					Ejector	Ejecteur	
4	●	-	-	1695653505	Kunststoffformteil	Pezzo Stampato D Plastica	
					Plastic Moulding	Piece Moulee En Plastique	
5	●	-	-	1695653506	Kunststoffformteil	Pezzo Stampato D Plastica	
					Plastic Moulding	Piece Moulee En Plastique	
6	○	-	-	169542934	Innensechsktsenkschraube	Vite svasata esagonale	
					Hex socket countrsk screw	Vis tête fraisée six pans	
7	●	-	-	1695655917	Potentiometer	Potenziometro	
					Potentiometer	Potentiometre	
8	○	-	-	169543092	Innensechsktflachkopfschr	Vite bombata esagonale	
					Hex Socket Button Screw	Vis tête cyl bombée plate	
9	●	-	-	1695615900	Ritzel	Pignone	
					Pinion	Pignon	
10	○	-	-	169540833	Gewindeformschraube	Vite Autofilettante	
					Thread-Forming Screw	Vis Autotaraudeuse	

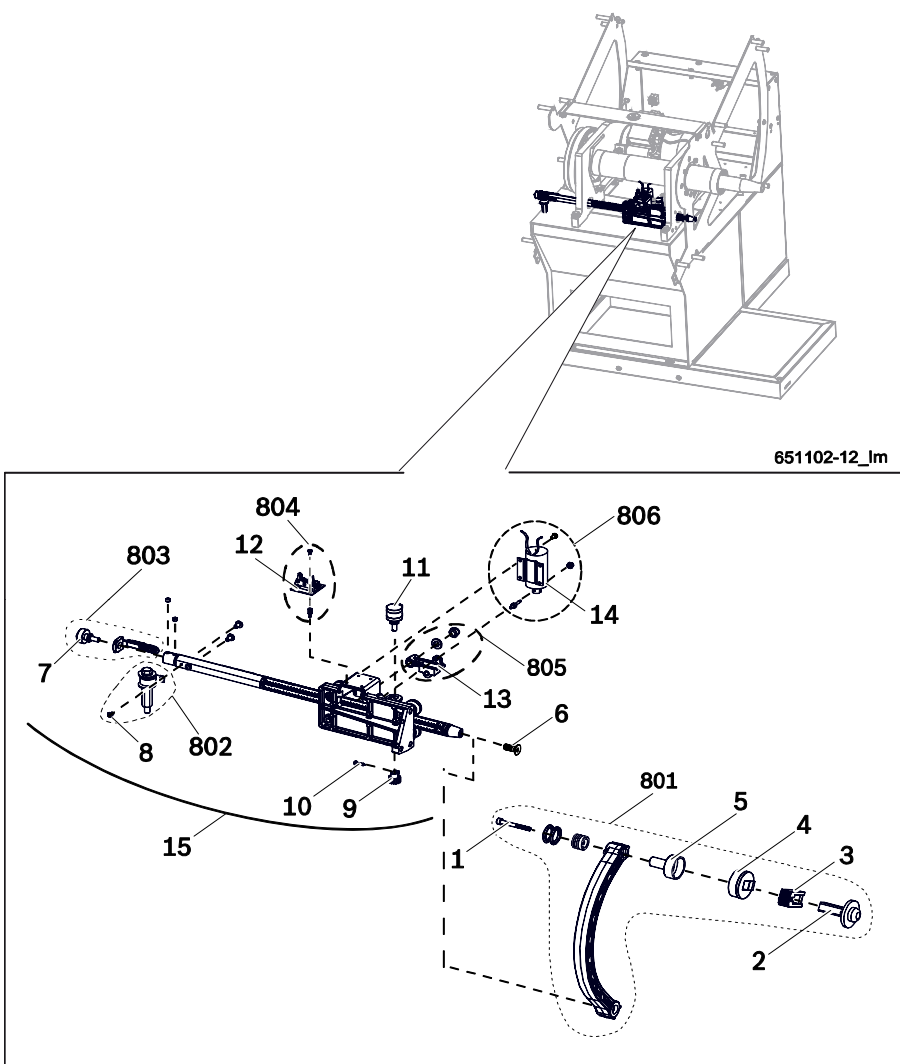
Pos.	Class	Intervall	Customer	Partnumber	BEZEICHNUNG (de)	IDENTIFICACION (es)	Drawing
					IDENTIFICATION (en)	IDENTIFICATION (fr)	
					Kommentar (de)	Comment (en)	
11	1	-	-	1695655370	Potentiometer	Potenziometro	
					Potentiometer	Potentiometre	
12	1	-	-	1695655493	Leiterplatte	Circuito Stampato	
					Printed Circuit Board	Circuit Imprime	
13	1	-	-	1695655921	Bremsanlage		
					braking system		
14	1	-	-	1695655367	Elektromagnet	Elettromagnete	
					Electromagnet	Electro-Aimant	
15	1	-	-	1695655498	Messvorrichtung	Dispositivo Di Misura	
					Measuring Tool	Instrument De Mesure	
801	1	-	-	1695655593	Montage	Montaggio	
					Assembly	Montage/Assemblage	
802	1	-	-	1695655756	Montage	Montaggio	
					Assembly	Montage/Assemblage	
803	1	-	-	1695655920	Abstützelement	Elemento Di Supporto	
					Support Element	Element De Support	

Pos.	Class	Intervall	Customer	Partnumber	BEZEICHNUNG (de)	IDENTIFICACION (es)
					IDENTIFICATION (en)	IDENTIFICATION (fr)
					Kommentar (de)	Comment (en)
1	●	-	-	1695656338	Abstützelement	Elemento Di Supporto
					Support Element	Element De Support
2	○	-	-	169541446	Innensechskantschraube	Vite cilindrica esagonal
					Hex Socket Head Cap Screw (No 2 pz.)	Vis cyl SixPans Creux CHC
3	●	-	-	1695655361	Schalter	Interruttore
					Switch	Commutateur
4	●	-	-	1695653035	Scheibe	Disco
					Washer	Rondelle
5	○	-	-	1695655982	Kunststoffabdeckung	
					plastic covering	
6	●	-	-	1695655927	Rahmen	Telaio
					Frame RAL.7016	Cadre
7	●	-	-	1695655563	Kunststoffformteil	Pezzo Stampato D Plastica
					Plastic Moulding	Piece Moulee En Plastique
8	○	-	-	169541326	Innensechsktflachkopfschr	Vite bombata esagonale
					Hex Socket Button Screw (No. 1 pz)	Vis tête cyl bombée plate
9	●	-	-	1695655562	Al-4Kantstange	Barra Quadrata In Allum
					Square Aluminum Bar	Carré D'aluminium
10	●	-	-	1695655946	Gummistopfen	Tampone Di Gomma
					Rubber Plug	Bouchon En Caoutchouc

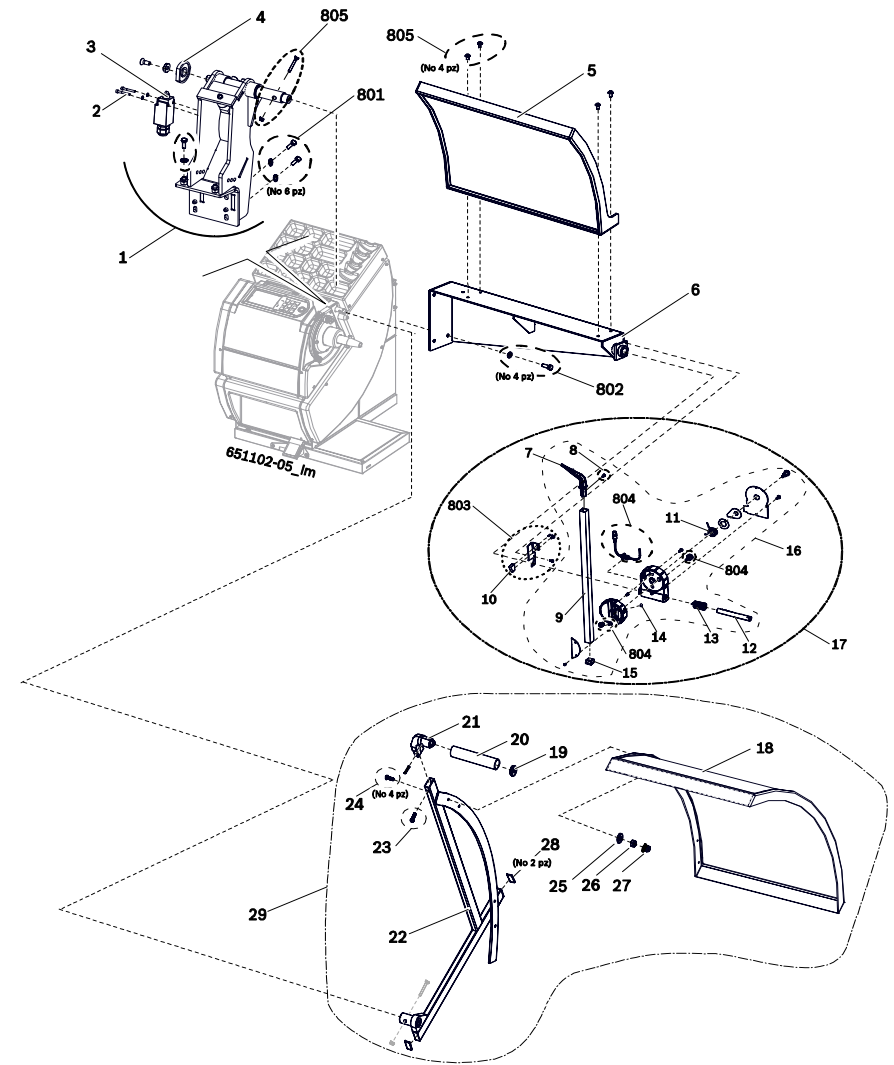

Pos.	Class	Intervall	Customer	Partnumber	BEZEICHNUNG (de)	IDENTIFICACION (es)
					IDENTIFICATION (en)	IDENTIFICATION (fr)
					Kommentar (de)	Comment (en)
11	●	-	-	1695655565	Feder	Molla
					Spring	Ressort
12	●	-	-	1695656320	Pin	Pin
					Pin	Broche
13	●	-	-	1695655564	Feder	Molla
					Spring	Ressort
14	○	-	-	1695043182	Pfropfen	Tappo
					Stopper	Bouchon
15	○	-	-	1695043183	Pfropfen	Tappo
					Stopper	Bouchon
16	●	-	-	1695655826	Messvorrichtung	Dispositivo Di Misura
					Measuring Tool	Instrument De Mesure
17	●	-	-	1695656315	Messvorrichtung	Dispositivo Di Misura
					Measuring Tool	Instrument De Mesure
18	○	-	-	1695656236	Schutz	Protezione
					Protection	Carter
19	○	-	-	1695627900	Kunststoffformteil	Pezzo Stampato D Plastica
					Plastic Moulding	Piece Moulee En Plastique
20	●	-	-	1695655258	Tubus	Tubo
					Tube	Tube

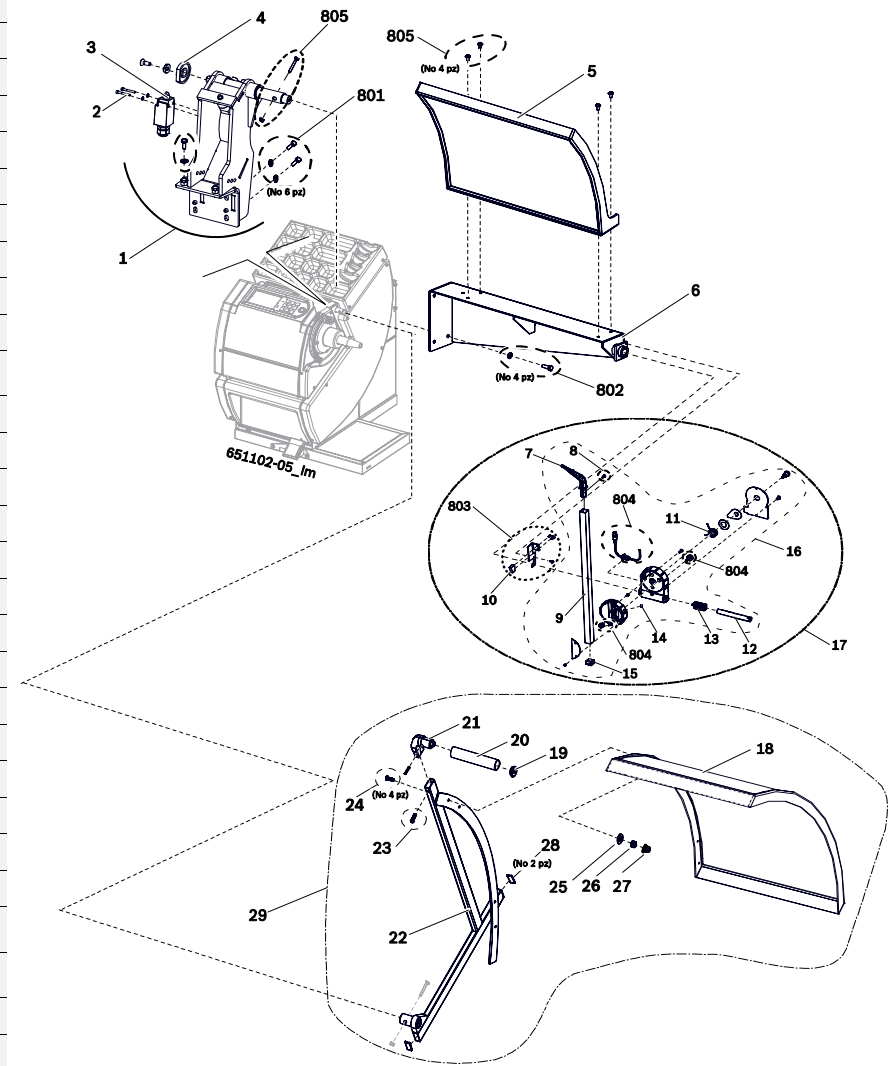

Pos.	Class	Intervall	Customer	Partnumber	BEZEICHNUNG (de)	IDENTIFICACION (es)
					IDENTIFICATION (en)	IDENTIFICATION (fr)
					Kommentar (de)	Comment (en)
21	●	-	-	1695656166	Stütze Support	Supporto Support
22	○	-	-	1695655980	Rahmen Frame	Telaio Cadre
23	○	-	-	169542237	Innensechsktflachkopfschr Hex Socket Button Screw	Vite bombata esagonale Vis tête cyl bombée plate
24	○	-	-	169543278	Innensechsktflachkopfschr Hex Socket Button Screw	Vite bombata esagonale Vis tête cyl bombée plate
25	○	-	-	1695002104	Scheibe Washer M6X20 ZNT BLACK	Disco Rondelle
26	○	-	-	169540029	Mutter Nut UNI 7474 M6 ZNT	Dado Erou
27	○	-	-	169543326	Spiralspannstift Coiled Spring Pin	Spina Elastica Goupille Spirale
28	○	-	-	169543123	Pfropfen Stopper	Tappo Bouchon
29	○	-	-	1695655956	Kunststoffabdeckung plastic covering	
801	○	-	-	1695655492	Befestigungsbausatz Mounting Kit	Gruppo Di Fissaggio Pieces De Fixation

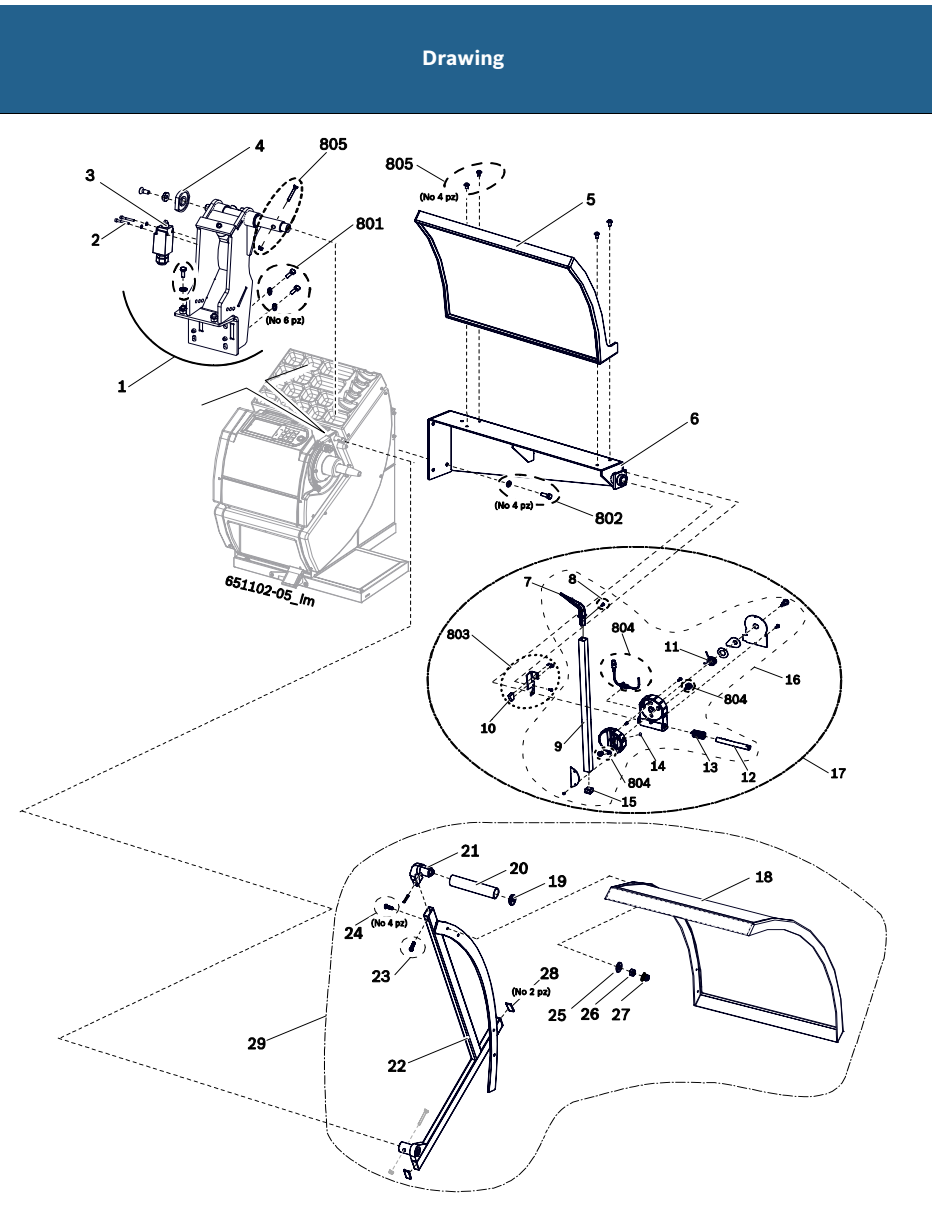

Pos.	Class	Intervall	Customer	Partnumber	BEZEICHNUNG (de)	IDENTIFICACION (es)	Drawing	
					IDENTIFICATION (en)	IDENTIFICACION (fr)		
					Kommentar (de)	Comment (en)		
802	○	-	-	1695655955	Befestigungsbausatz Mounting Kit	Gruppo Di Fissaggio Pieces De Fixation		
803	○	-	-	1695656652	Ersatzteilsatz Service kit	Kit Pezzi Di Ricambio Jeu De Rechanges		
804	○	-	-	1695656653	Ersatzteilsatz Service kit	Kit Pezzi Di Ricambio Jeu De Rechanges		
805	○	-	-	1695655486	Befestigungsbausatz Mounting Kit	Gruppo Di Fissaggio Pieces De Fixation		

Pos.	Class	Intervall	Customer	Partnumber	BEZEICHNUNG (de)	IDENTIFICACION (es)	Drawing
					IDENTIFICATION (en)	IDENTIFICATION (fr)	
					Kommentar (de)	Comment (en)	
1	●	-	-	1695655261	Netzteil	Alimentatore	
					Power Stage	Bloc d'alimentation	
2	●	-	-	1695645500	Halterung	Supporto	
					Holder	Fixation	
3	●	-	-	1695655403	Leiterplatte	Circuito Stampato	
					Printed Circuit Board	Circuit Imprime	
4	●	-	-	1695655674	Leiterplatte	Circuito Stampato	
					Printed Circuit Board	Circuit Imprime	
5	○	-	-	1695655675	Befestigungsbausatz	Gruppo Di Fissaggio	
					Mounting Kit	Pieces De Fixation	
801	○	-	-	1695655454	Befestigungsbausatz	Gruppo Di Fissaggio	
					Mounting Kit	Pieces De Fixation	
A	●	-	-	1695655364	Leistungskabel		
					Power Cable	Câble de puissance	
M	●	-	-	1695654463	Elektr Leitung	Cavo Elettriso	
					Cable	Cable	

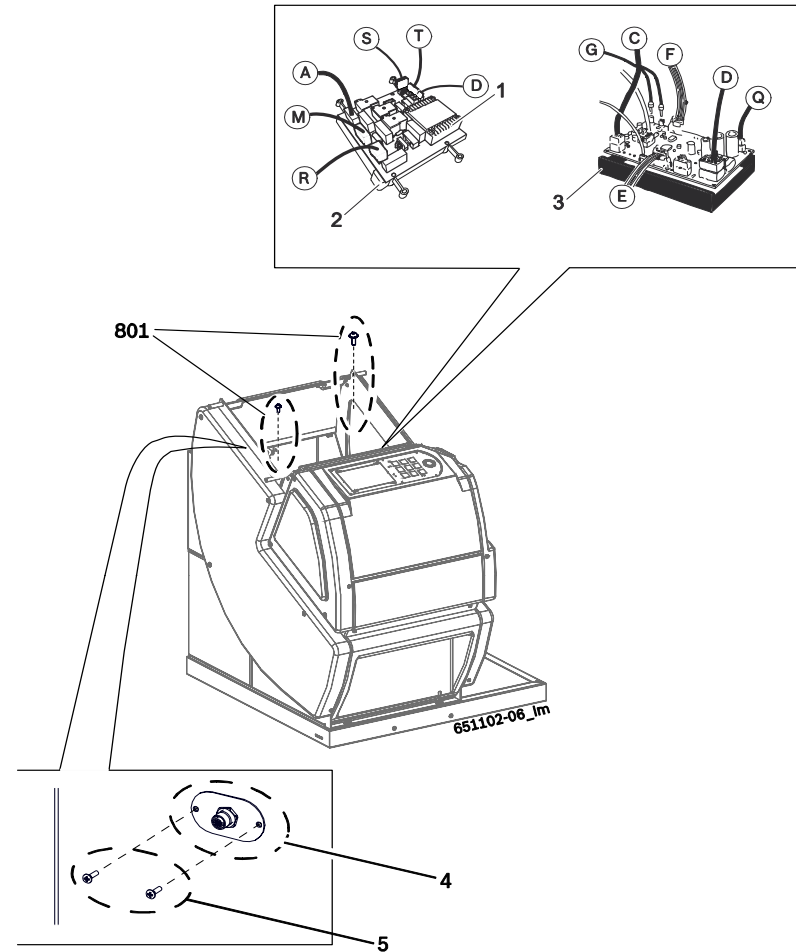



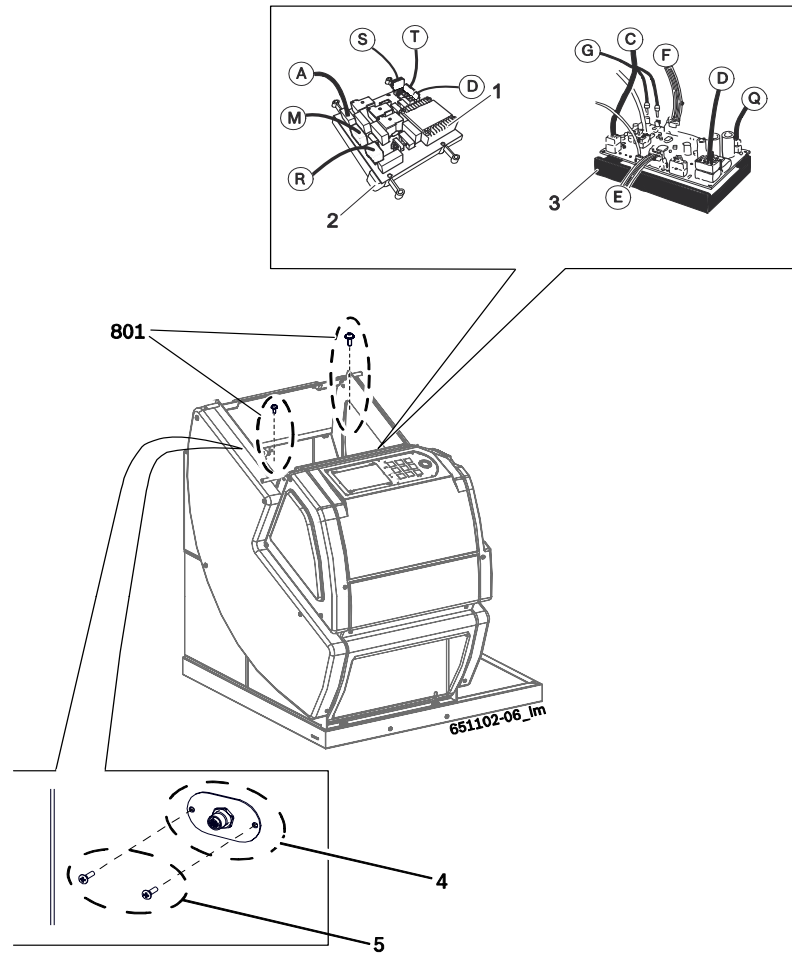











Pos.	Class	Intervall	Customer	Partnumber	BEZEICHNUNG (de)	IDENTIFICACION (es)	Drawing
					IDENTIFICATION (en)	IDENTIFICATION (fr)	
					Kommentar (de)	Comment (en)	
R	1	-	-	1695655477	Elektr Leitung	Cavo Elettriso	
					Cable	Cable	
					(230V)		
R*	1	-	-	1695655480	Kabelsatz	Set Di Cavi	
					Cable Set	Jeu De Cable	
					(110V)		
S	1	-	-	1695655361	Schalter	Interruttore	
					Switch	Commutateur	
T	1	-	-	1695655363	Elektr Leitung	Cavo Elettriso	
					Cable	Cable	
D	1	-	-	1695655354	Elektr Leitung	Cavo Elettriso	
					Cable	Cable	
E	1	-	-	1695654434	Lichtschranke	Barra Fotoelettrica	
					Photoelec. Light Barrier	Barriere Photoelectrique	
F	1	-	-	1695655507	Elektr Leitung	Cavo Elettriso	
					Cable	Cable	
G	1	-	-	1695654776	Wegaufnehmer	Rilevatore Di Percorrenza	
					Displacement sensor	Capteur De Deplacement	
G	1	-	-	1695654777	Wegaufnehmer	Rilevatore Di Percorrenza	
					Displacement sensor	Capteur De Deplacement	
					(Red)		
					(Black)		



Pos.	Class	Intervall	Customer	Partnumber	BEZEICHNUNG (de)	IDENTIFICACION (es)	Drawing	
					IDENTIFICATION (en)	IDENTIFICATION (fr)		
					Kommentar (de)	Comment (en)		
C	1	-	-	1695654444	Elektr Leitung	Cavo Elettriso		
					Cable	Cable		
Q	1	-	-	1695655367	Elektromagnet	Elettromagnete		
					Electromagnet	Electro-Aimant		

Pos.	Class	Intervall	Customer	Partnumber	BEZEICHNUNG (de)	IDENTIFICACION (es)	Drawing
					IDENTIFICATION (en)	IDENTIFICATION (fr)	
					Kommentar (de)	Comment (en)	
1	O	-	-	1695629400	Lehre	calibro	EQUIPMENT 
					Gauge	calibre	
2	O	-	-	1695606500	Zange	Pinza	
					Pair Of Tongs	Tenaille	
3	O	-	-	1695602700	Messschieber	Calibro	
					Caliper	Pied à coulisse	
4	O	-	-	1695654377	Ausgleichgewicht	Contrappeso	
					Counterweight	Contrepoids	
5	O	-	-	1695655496	Zapfen	Perno	
					Pivot	Pivot	
6	O	-	-	169540641	Augbolzen	Bullone A Occhio	
					Eyebolt	Boulon A Oeillet	
					M10 ZNT		
7	O	-	-	1695653510	Kunststoffformteil	Pezzo Stampato D Plastica	
					Plastic Moulding	Piece Moulee En Plastique	
8	O	-	-	1695653511	Kunststoffformteil	Pezzo Stampato D Plastica	
					Plastic Moulding	Piece Moulee En Plastique	
9	O	-	-	1695655338	Verlaengerungsleitung	Prolunga	
					Extension Cable	Cordon Prolongateur	
					M10 ZNT		



651096-11_Im

Pos.	Class	Intervall	Customer	Partnumber	BEZEICHNUNG (de)	IDENTIFICACION (es)	Drawing
					IDENTIFICATION (en)	IDENTIFICATION (fr)	
					Kommentar (de)	Comment (en)	
11	O	-	-	1695652991	Leistungskabel		EQUIPMENT
					Power Cable	Câble de puissance	
12	O	-	-	1695042398	Anschlussstück	Raccordo	1  2  3 
					Connecting Piece	Raccord	
13	O	-	-	169520709	Innensechsktsensschraube	Vite svasata esagonale	4  5  6 
					Hex socket countrsk screw	Vis tête fraisée six pans	
14	O	-	-	169542207	UNI 5933 M8X20 BRT		7  8  9 
					Innensechskantschraube	Vite cilindrica esagonal	
15	O	-	-	1695656585	Hex Socket Head Cap Screw	Vis cyl SixPans Creux CHC	10  11  12 
					UNI 5931 M5X80 TF ZNT		
801	O	-	-	1695655582	Hebel	Leva	13  14 
					Lever	Levier	
801	O	-	-	1695655582	Zubehörsatz	Serie Accessori	801 
					Accessory Set	jeu d'accessoires	

651096-11_lm

Pos.	Class	Intervall	Customer	Partnumber	BEZEICHNUNG (de)	IDENTIFICACION (es)	Drawing
					IDENTIFICATION (en)	IDENTIFICATION (fr)	
					Kommentar (de)	Comment (en)	
801	O	-	-	1695612100	Schnellspannkonus		FLANGE ACCESSORIES
					fast-action cone		
802	O	-	-	1695654042	Mutter	Dado	
					Nut	Ecrou	
					M101,25 MM		
803	O	-	-	1695653420	Flansch	Flangia	
					Flange	Bride	
804	O	-	-	1695654043	Flansch	Flangia	
					Flange	Bride	
805	O	-	-	1695653827	Flansch	Flangia	
					Flange	Bride	

651096-07_lm

Pos.	Class	Intervall	Customer	Partnumber	BEZEICHNUNG (de)	IDENTIFICACION (es)	Drawing
					IDENTIFICATION (en)	IDENTIFICACION (fr)	
					Kommentar (de)	Comment (en)	
801	○	-	-	1695654039	Flansch	Flangia	<h3>MOTORCYCLE ACCESSORIES</h3>  <p>801</p>  <p>802</p>  <p>803</p> <p>651096-08_lm</p>
					Flange	Bride	
802	○	-	-	1695653430	Welle	Albero	
					Shaft	Arbre	
803	○	-	-	1695654060	D.10MM		
					Spannsatz	Set Pezzi Di Serraggio	
					Tensioner Parts Set	Jeu De Pieces De Serrage	

Pos.	Class	Intervall	Customer	Partnumber	BEZEICHNUNG (de)	IDENTIFICACION (es)	Drawing
					IDENTIFICATION (en)	IDENTIFICATION (fr)	
					Kommentar (de)	Comment (en)	
801	O	-	-	1695655293	Zentrierkonus		CONI, RINGS & WEIGHTS ACCESSORIES 
					centering cone		
					DIM.120-174		
802	O	-	-	1695654376	Ausgleichgewicht	Contrappeso	
					Counterweight	Contrepoids	
					60 gr. ZNT		
803	O	-	-	1695653449	Zentrierkonus		
					centering cone		
					DIM.89-132		
804	O	-	-	1695606300	Zentrierkonus		
					centering cone		
					DIM.120-174		
805	O	-	-	1695606200	Distanzring	Spessore	
					Spacer Ring	Bague Entretoise	
806	O	-	-	1695656571	Einpassring	Anello Di Centraggio	
					Fitting Ring	Bague D'ajustage	
					DIAM.50-60/66/71 MM		

651096-09_Im

Date	Author	Modification
28/07/2011	Benedettini	Newly created



Robert Bosch GmbH
Diagnostics
Franz-Oechsle-Str. 4
73207 Plochingen
DEUTSCHLAND
www.bosch.com

1 695 656 430 - 2011-07-12